

Series A99 Temperature Sensors

Introuction

The A99 Temperature sensor line offers an economical solution for a wide variety of temperature sensing needs, in the cooling, heating, ventilation and air conditioning application field.

The A99 temperature sensor line includes various models, such as:

- bulb sensors
- bulb well sensors
- room sensors
- outdoor sensors
- duct sensors
- rod sensors
- strap-on sensors

The A99 series is based on a PTC- thermistor-sensing element. Each sensor is calibrated which results in a high accuracy over a wide temperature range.

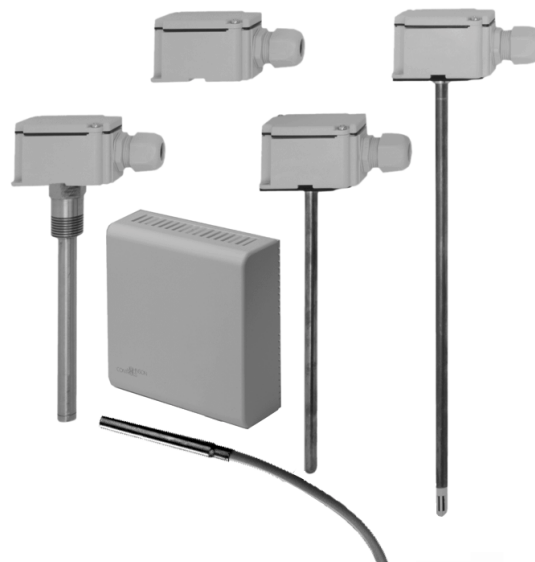

A99 Temperature Sensors

Features and Benefits

<input type="checkbox"/> Wide range of enclosures for sensing elements	Various models are available to match a wide variety of temperature sensing needs
<input type="checkbox"/> PG 13,5 cable inlet for all models with polycarbonate housing	Protection against humidity and firm fixation of cable
<input type="checkbox"/> Very accurate sensing element	Provides suitable performance for a wide variety control set ups
<input type="checkbox"/> 3 types of sensor cable	PVC, PVC with shield or silicon cable allows mounting at various applications
<input type="checkbox"/> High resistance variation per °C	Cable extension gives a negligible deviation
<input type="checkbox"/> Several sensor accessories are available	Allows easy tailoring to a variety of mounting configurations
<input type="checkbox"/> Stainless steel sensor bulb	No corrosion in aggressive environments

Description

A99 series includes a high sensitive calibrated PTC thermistor element.

Note:

Normal PTC thermistors (Non calibrated) have a high resistance variation per °C that allows extending cable length with negligible effects and without the need for compensation circuits. Also, the controller-input circuit doesn't need to be that sensitive. But normal PTC sensors are not very accurate.

PT-100 or PT-1000 sensors (Platinum based) are more accurate, but have a low resistance variation per °C.

The A99 series combines the advantages of PT-100 sensors and normal PTC sensors. Each PTC thermistor element is calibrated according to a standard graph. This increases accuracy and makes exchanging of the sensor without recalibration very easy.

A99 series are for use with Johnson Controls System 27 NOVA, MR/MS series, R78, A255 electronic control modules, DX-9100, XP-9102, XPA-4x1 and XPA-8x1.

Mounting instructions

The sensors can be mounted in virtually any position.

For mounting follow the instructions below:

- Locate the sensors, where they will be exposed to representative conditions.
- Use a thermal conductive paste where appropriate to improve reaction times.
- The sensor should not be exposed to direct radiation (lamps, radiators, etc.), draughts or direct sunlight, since it would lead to incorrect measurement.

WARNING

When wiring or servicing make sure that the power supply is switched off.

Wiring instructions

For wiring follow the instructions below:

- Keep high and low voltage wiring separated. For applications in critical industrial environments, use a shielded sensor cable. Connect one side of the shield to earth (ground).
- When the sensor cable is lengthened the additional wiring resistance may affect the output reading. Use the following procedure to calculate the effects:
 - a) Read the resistance value at the requested temperature setting
 - b) The cable resistance can be calculated using the formula:

$$R = L \times 0,035 \quad (\Omega)$$

A

Where L = Cable length in meters

A = Cross section in mm²:

- c) This cable resistance should be added to the resistance value mentioned in the table on page 3.
- d) Refer to the table on page 3 and note the temperature at the calculated resistance.

Example:

The sensor is connected to a 100 m cable with a cross section of 1mm². The setpoint temperature is 20°C.

- a) The sensor resistance at 20°C is 997Ω
- b) The cable resistance is

$$(100 \times 0,035)/1 = 3,5\Omega$$
- c) The total resistance is 1000,5Ω.
- d) 1000,5Ω equals a temperature of 20,5°C

Trouble shooting

Check sensor for proper resistance.

If system performance indicates a problem, a check for proper sensor resistance will quickly determine if the sensor or the controller is at fault.

To check the sensor resistance:

- 1 Disconnect the sensor from the controller
- 2 Take a temperature reading at the sensor location. Be sure to let the thermometer stabilise before taking a reading
- 3 Use an ohmmeter to take a reading of the resistance across the two sensor leads. (Note: the max. current flow through the sensor should be <10mA)
- 4 Consult Temperature Resistance Table. (Include cable resistance when sensor cable is lengthened).

If the actual performance of the sensor deviates substantially from that, what is represented in the table, the sensor must be replaced.

Sensor Accuracy

Sensor accuracy is within 0.5 °C between -15 and 75 °C. tolerance increases at temperatures outside this range, as shown below.

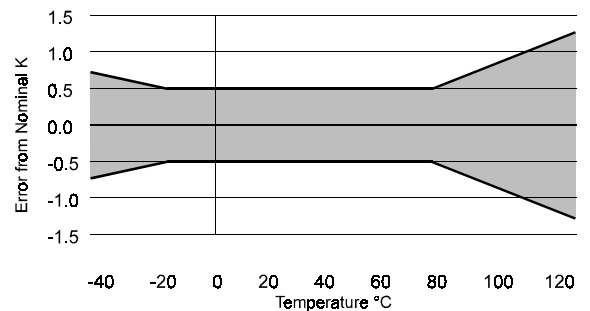

Temperature versus resistance

Temperature (°C)	Resistance (Ω)
-40	613
-35	640
-30	668
-25	697
-20	727
-15	758
-10	789
-5	822
0	855
5	889
10	924
15	960
20	997
25	1035
30	1074
35	1113

Temperature (°C)	Resistance (Ω)
40	1153
45	1194
50	1236
55	1279
60	1323
65	1368
70	1413
75	1459
80	1506
85	1554
90	1602
95	1652
100	1702
105	1753
110	1805
115	1857
120	1909

Type number selection table

A99x-91xx series with PTC sensing element

Order number	Type	Material	Figure
A99BA-200C	Bulb	2m PVC shielded cable	1
A99BB-25C	Bulb	0,25m PVC cable	1
A99BB-200C	Bulb	2m PVC cable	1
A99BB-300C	Bulb	3m PVC cable	1
A99BB-500C	Bulb	5m PVC cable	1
A99BB-600C	Bulb	6m PVC cable	1
A99BC-300C	Bulb	3m silicon cable	1
A99DY-200C	Duct/Rod fast response	Copper rod, Polycarbonate enclosure	6
A99EY-1C	Outdoor	Polycarbonate	3
A99LY-160C	Rod, 160mm	Copper rod, Polycarbonate enclosure	7
A99LY-200C	Rod, 200mm	Copper rod, Polycarbonate enclosure	7
A99LY-300C	Rod, 300mm	Copper rod, Polycarbonate enclosure	7
A99LY-500C	Rod, 500mm	Copper rod, Polycarbonate enclosure	7
A99RY-1C	Room	ABS	2
A99SY-1C	Strap-On	Brass, Polycarbonate enclosure	4
A99WD-52C	Bulbwell, 52 mm	Brass bulbwell, Polycarbonate enclosure	5
A99WD-143C	Bulbwell, 143 mm	Brass bulbwell, Polycarbonate enclosure	5
A99WE-143C	Bulbwell, 143 mm	Stainless steel bulbwell, Polycarbonate enclosure	5

Optional accessories

Order number	Description	Figure	Can be used in combination with:
HSG012N600	Outdoor housing	14	A99Bx-xx (see fig 1)
SHL10A-603R	Outdoor shield	8	A99Bx-xx (see fig 1)
GRD004N611	A99RY-1C enclosure	2	A99Bx-xx (see fig 1)
TS-9100-8950	Duct flange	9	A99DY-200C, A99LY-x00C (see fig 6,7)
TS-9100-8901	Well, Copper L=120mm	12	A99LY-x00C (see fig 7)
TS-9100-8911	Well, St. Steel L=120mm	11	A99LY-x00C (see fig 7)
TS-9100-8902	Well, Copper L=200mm	13	A99LY-x00C (see fig 7)
TS-9100-8912	Well, St. Steel L=200mm	11	A99LY-x00C (see fig 7)
TS-9100-8905	Well, Copper L=50mm	12	A99Bx-xx (see fig 1)
TS-9100-8915	Well, St. Steel L=50mm	10	A99Bx-xx (see fig 1)
A99-CLP-1	Surface mount	15	A99Bx-xx (see fig 1)

Dimensions (mm)

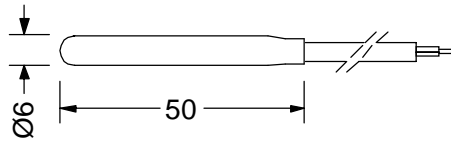

Fig. 1 Bulb

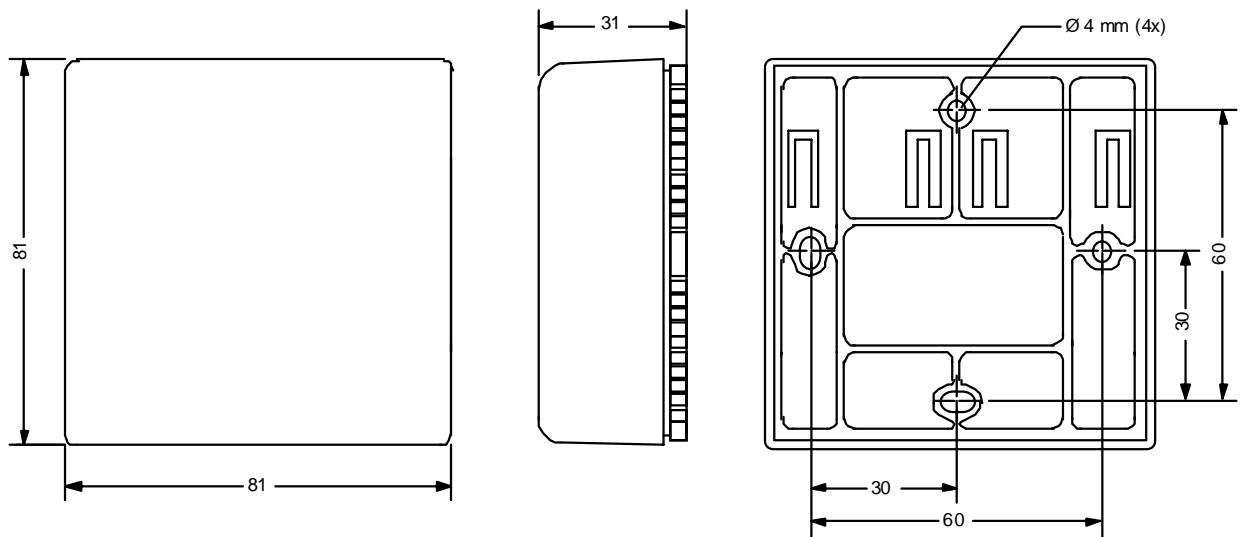

Fig. 2 Room Sensor (Colour RAL9010)

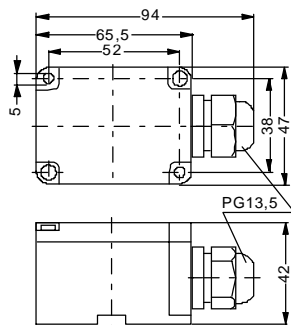

Fig 3
Outdoor Sensor

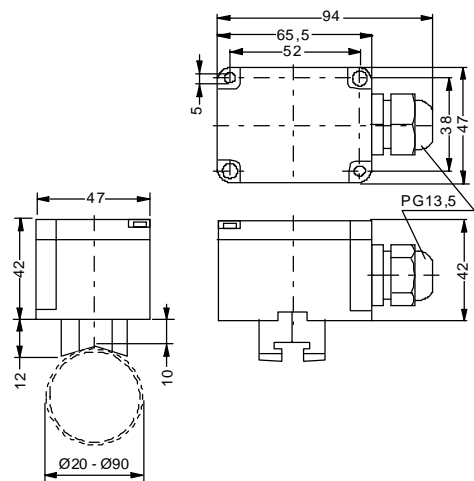

Fig 4
Strap-on Sensor

Dimensions continued (mm)

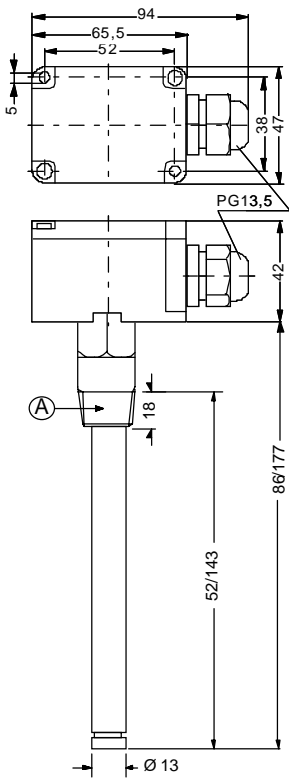

Fig. 5 Bulbwell
A = 1/2 - 14 NP

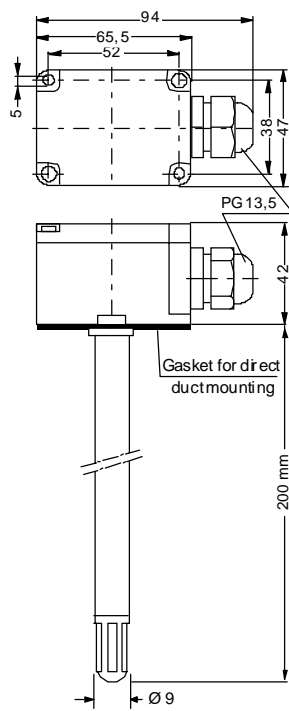

Fig. 6 Duct/fast response sensor

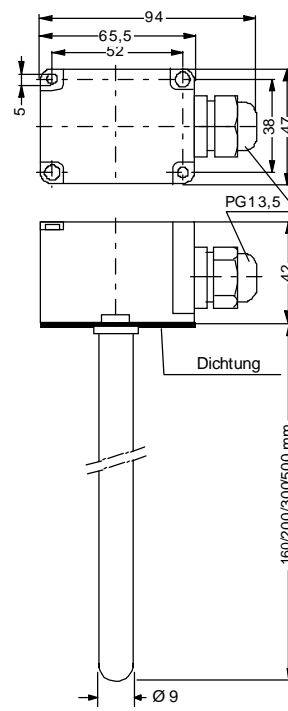

Fig 7 Rod Sensor

Dimensions Accessories

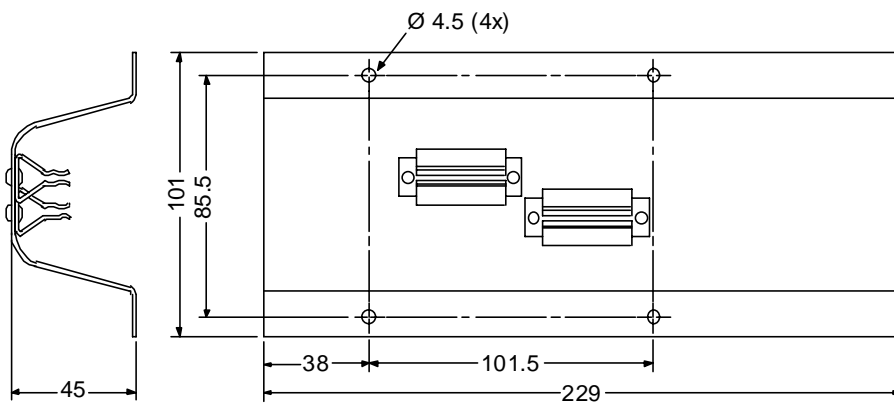

Fig. 8 Outdoor shield

Dimensions Accessories (cont.)

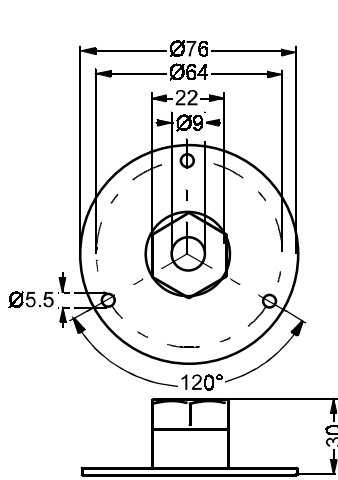

Fig. 9
Duct flange TS-9100-8950

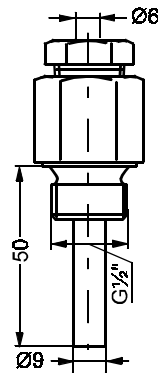

Fig. 10
Stainless steel wells TS-9100-891x

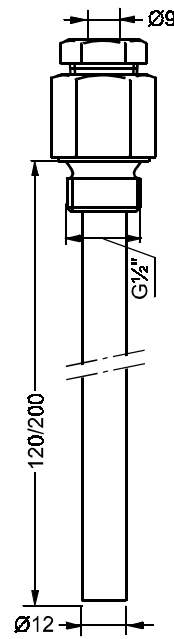

Fig. 11

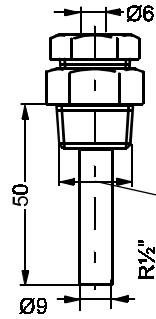

Fig. 12
Copper wells TS-9100-890x

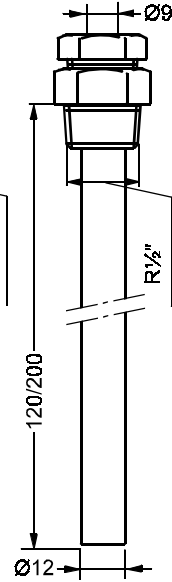

Fig. 13

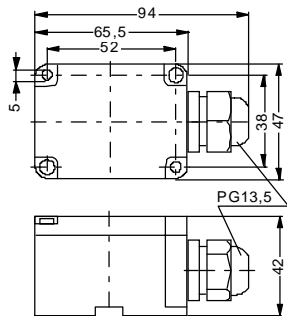

Fig 14
Outdoor Housing

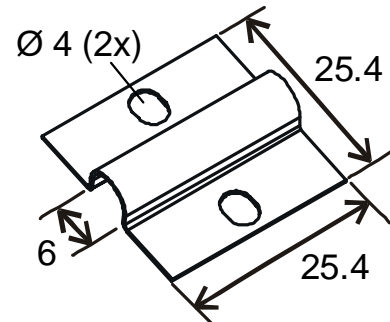

Fig 15
Surface Mount Clip

Specifications

Product	A99 series	
Temperature range	Bulb + PVC cable (A99BA-xx; A99BB-xx)	-40 to +100°C
	Bulb + silicon cable (A99BC-xx)	-50 to +120°C
	Rod (A99LY-xx)	-50 to +100°C (*1)
	Bulbwell (A99Wx-xx)	-50 to +100°C (*1)
	Duct/Rod fast response (A99DY-xx)	-20 to + 60°C
	Room (A99RY-xx)	-20 to + 60°C
	Outdoor (A99EY-xx)	-40 to +60°C
	Strap-on (A99SY-xx)	-40 to +60°C
Accuracy	See graph sensor accuracy pg.3	
Lead wires	Bulb type A99BB-xx	PVC: 2 x 0,33 mm ²
	Bulb type A99BA-xx	PVC with shield; 2 x 0,33 mm ²
	Bulb type A99BC-xx	Silicon: 2 x 0,33 mm ²
IP rating	Bulb (A99Bx-xx)	IP 68
	Rod (A99LY-xx)	IP 54 ^(*)
	Bulbwell (A99Wx-xx)	IP 54 ^(*)
	Duct/Rod fast response (A99DY-xx)	IP 30
	Room (A99RY-xx)	IP 30
	Outdoor (A99EY-xx)	IP 54
	Strap-on (A99SY-xx)	IP 54

(*1) Indicated temperature range refers to sensing part only. Plastic housing withstands temperatures from -40 to +60°C

(*2) Sensing part has IP rating IP68

The performance specifications are nominal and conform to acceptable industry standards. For applications at conditions beyond these specifications, consult the local Johnson Controls office or representative. Johnson Controls shall not be liable for damages resulting from misapplication or misuse of its products.



Johnson Controls International, Inc.

Headquarters: Milwaukee, WI, USA
 European Headquarters: Westendhof 8, 45143 Essen, Germany
 European Factories: Lomagna (Italy), Leeuwarden (The Netherlands) and Essen (Germany)
 Branch Offices: Principal European Cities.
 This document is subject to change

Printed in Europe