

## VG4000 Series High Capacity / High Close-off Zone Valves

### Introduction

*VG4000 Series High Capacity / High Close-off Zone Valves are primarily designed to regulate the flow of water in response to the demand of a controller in zone, fan coil, and Variable Air Volume (VAV) reheat coil applications. The valves can be used in combination with VA-7010 electric on/off actuators, VA-7040 thermal actuators and VA-7450 incremental or proportional actuators. VG4000 Series Valves are available in Normally Open (N.O.), Normally Closed (N.C.), or three-way mixing configurations.*

*Refer to either the "VA-7010" bulletin, "VA-7040" bulletin or the "VA-7450" bulletin.*



**VG4000 Series Zone Valves**

Features and Benefits	
<input type="checkbox"/> <b>Cast Bronze Body and Stainless Steel Stem and Spring</b>	Ensures long life
<input type="checkbox"/> <b>EPT Rubber Plug for Bubble-Tight Shutoff</b>	Maximizes energy savings
<input type="checkbox"/> <b>Easy, Field-Replaceable Packing</b>	Shortens service time
<input type="checkbox"/> <b>Actuator Can Be Field Installed After Piping</b>	Simplifies installation in confined locations
<input type="checkbox"/> <b>Built-In Return Spring for VA-7010 Actuators</b>	Allows the valve to return to normal position when the actuator is de-energized
<input type="checkbox"/> <b>Selectable flow characteristic in combination with VA-7452 actuators</b>	Provides desired controllability

# Ordering data

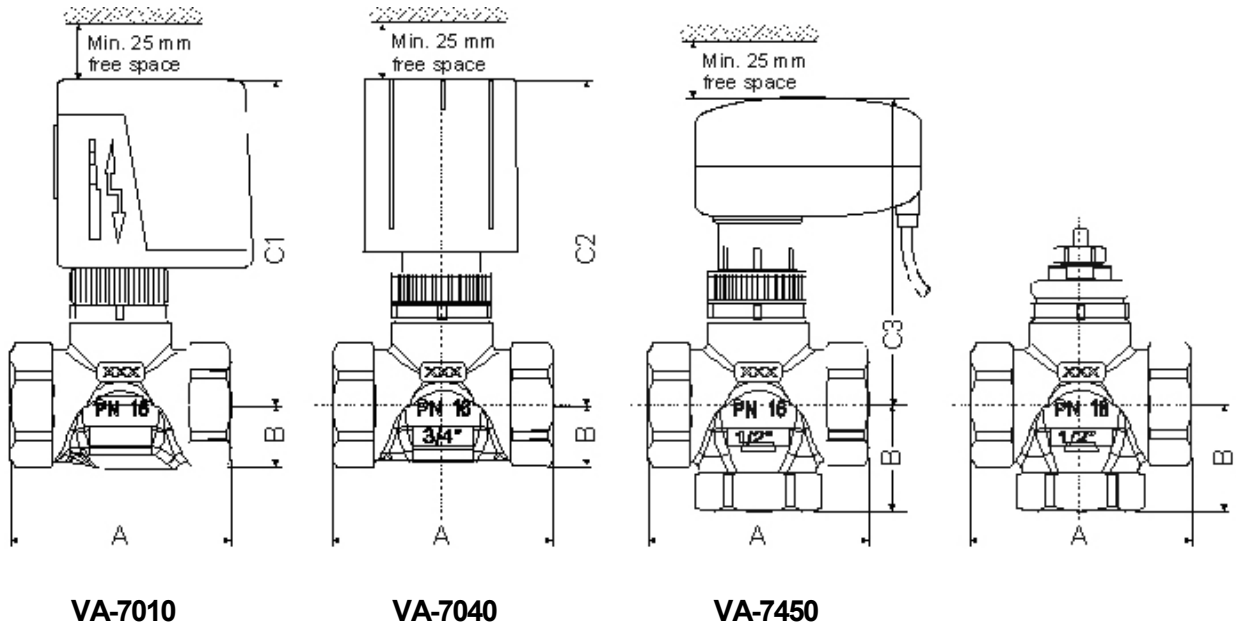

## Threaded Female Connection

Ordering code	Body Type	Body Size	Connection Size	Kvs	Close-Off Pressure (kPa)	Dimensions (mm)				
						A	B	C1 (VA-7010)	C2 (VA-7040)	C3 (VA-7450)
VG42y0FC	2-way PDTC (NO)	DN15	1/2"	2.5	340	66	19	111	110	105
VG42y0GC		DN20	3/4"	3.0						
VG44y0FC	2-way PDTO (NC)	DN15	1/2"	2.5						
VG44y0GC		DN20	3/4"	3.0						
VG48y0FC	3-way Mixing	DN15	1/2"	2.5	340 (200 kPa in NO Port)	32				
VG48y0GC		DN20	3/4"	3.0						

### Threads

- y = 0: BSP parallel
- y = 2: BSP taper
- y = 4: NPT

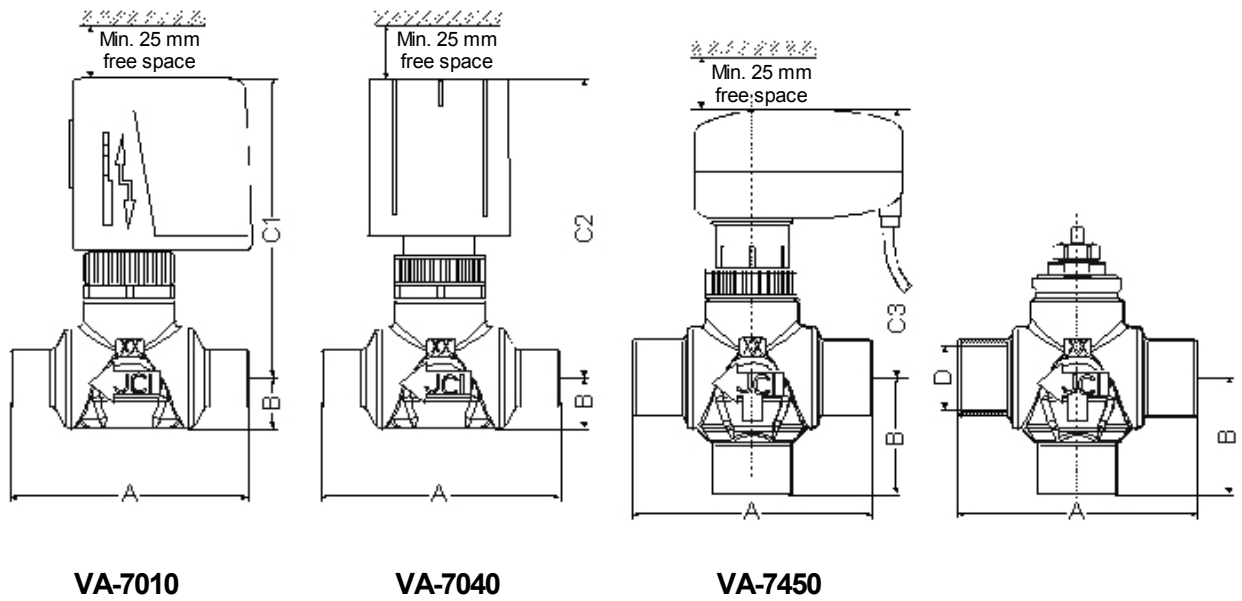

**Sweat Connection**

Ordering code	Body Type	Body Size	Connection Size	Kv <sub>s</sub>	Close-Off Pressure (kPa)	Dimensions (mm)				
						A	B	C1 (VA-7010)	C2 (VA-7040)	C3 (VA-7450)
VG4270FC	2-way PDTC (NO)	DN15	1/2"	2.4	340	78	15	111	99	94
VG4270GC		DN20	3/4"	2.8			19		102	97
VG4470FC	2-way PDTO (NC)	DN15	1/2"	2.4			15		99	94
VG4470GC		DN20	3/4"	2.8			19		102	97
VG4870FC	3-way Mixing	DN15	1/2"	2.4			29		99	94
VG4870GC		DN20	3/4"	2.8			39		102	97

## Maintenance and service

Description	Code Number
Packing Nut integral o-ring	VG4000-1

## Valve selection

The valve size for water applications can be defined using the diagrams below, where the intersection of the pressure drop over the completely open valve and the flow has to stay within the white area.

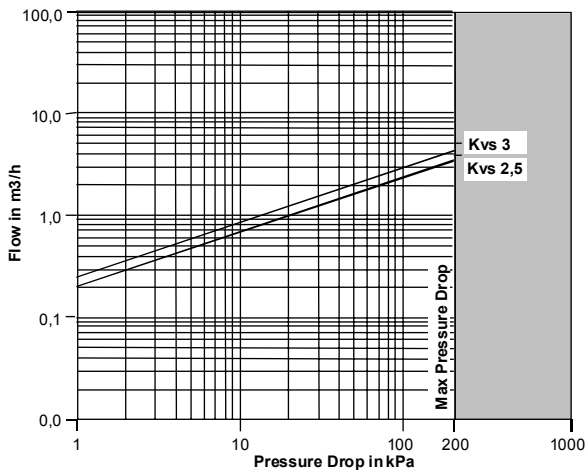

**Kvs selection diagram in SI units, full seat**

## Valve - Actuators combinations

The VG4000 valve series are designed to be used with the VA-7010 series electric on/off, VA-7040 thermal and VA-7450 electronic modulating actuators. The ordering data for these actuators are as follows:

### ● VA-7010 Series Electric Actuator

VA-7010-810x	Supply voltage
VA-7010-8101	24 VAC
VA-7010-8103	230 VAC

See "VA-7010" bulletin for more information.

### ● VA-7040 Series Thermal Actuator

VA-7040-2x	Supply voltage
VA-7040-21	24 VAC or 24 VDC
VA-7040-23	230 VAC

See "VA-7040" bulletin for more information.

### ● VA-7450 Series Electronic Actuator

Item Code	Features
<b>VA-7450-1001</b>	<ul style="list-style-type: none"> <li>• Incremental control</li> <li>• Anti-sticking cycle disabled</li> </ul>
<b>VA-7452-1001</b>	<ul style="list-style-type: none"> <li>• Proportional control</li> <li>• Self-calibrating</li> <li>• 0 to 10 VDC input signal</li> <li>• Direct Acting</li> <li>• Adjusted for almost linear combined flow characteristic in combination with VG series terminal unit valves.</li> <li>• Anti-sticking cycle disabled</li> </ul>
<b>VA-7452-9001</b>	<ul style="list-style-type: none"> <li>• Proportional control</li> <li>• Self-calibrating</li> <li>• Selectable input signals for range splitting (0 to 10, 0 to 5, 5 to 10 VDC).</li> <li>• Reversible Action</li> <li>• Selectable combined flow characteristic in combination with VG series terminal unit valves</li> <li>• Selectable Anti-sticking cycle</li> </ul>









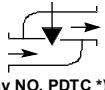

See "VA-7450" bulletin for more information.

# Operation

These valves are used for hot or cold water and for water glycol mixtures up to 30%.

**Note:** These valves are intended to control equipment under normal operating conditions. Where failure or malfunction of the valves could lead to an abnormal operating condition that could cause personal injury or damage to the equipment or other property, other devices (limit or safety controls) or systems (alarm or supervisory systems) intended to warn of or protect against failure or malfunction of the valves must be incorporated into and maintained as part of the control system.

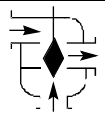
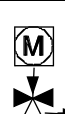
When the stem of the valve is moved down by the actuator against the return spring, it opens the N.C. port or closes the N.O. port of a valve.

Valve Type	Stem movement / flow	 = flow  = no flow
 2-way NO, PDTC *)	 Actuator stem down  Actuator stem up	
 2-way NC, PDT0 *)	 Actuator stem down  Actuator stem up	
 3-way, mixing	 Actuator stem down  Actuator stem up	

\*) PDTC = Push down to close  
 PDT0 = Push down to open

## Mounting instructions

### General installation guidelines

In addition to general installation instructions, please observe the following points:

- Ensure that valve body and piping are free of impurities.
- Pay attention to position of the valve relative to the flow direction.
- Note arrows on valve body.
- Ensure that threaded connections of valve and piping are tightened.
- Ensure installation without tension and torque.
- Do not use the valve as a step or fixation point. Only piping supports it.
- Protect valve from dust or dirt on construction sites.
- Provide strainer or filter upstream of valve.
- Use compensators to balance thermal expansion of piping.
- Ensure that stem thread and shaft are kept free of paint.

### Installation site information

The valve installation site should be easily accessible and provide sufficient room for service and removal of actuators. Manual shut-off valves should be located up and downstream of the control valve, to facilitate service and repairs without drainage of the piping system. The control valve should preferably be installed in vertical or horizontal position.

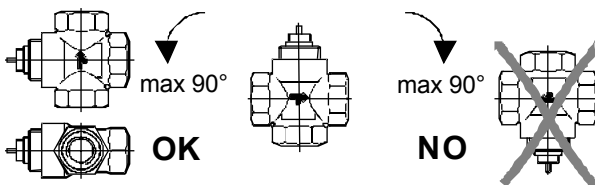

Piping should be insulated to protect actuators against high temperatures. Insulation should leave sufficient room for service of stem packing. To ensure trouble free function of the control valves the pipe immediately upstream of the valve should be straight for the length of at least 2x DN and the pipe immediately downstream straight for the length at least 6x DN.

### Valve removal

In addition to general mounting guidelines the following points should be observed:

- Pressure free piping system
- Cooled fluid
- Drained piping system
- With corrosive or aggressive fluids, the piping system should be vented.
- Work to be performed by qualified personnel only.

### Commissioning

Prior to commissioning check information on material, pressure, temperature and flow direction in conjunction with the installation piping system plan. Impurities in the piping system and valves, such as dirt, welding beads etc. will cause the system to leak.

Prior to commissioning a new installation or re-commissioning after repairs or service, ensure that:

- Correct installation- and assembly work has been completed.
- Only qualified personnel carry out commissioning.
- Correct functional position of the valve is ascertained.
- Maintenance of existing protective facilities is carried out.

## Specifications

<b>Product</b> VG4000 Series			
<b>Models</b>	<b>VG42xx</b>	<b>VG44xx</b>	<b>VG48xx</b>
<b>Body type</b>	2-way PDTC (NO)	2-way PDTO (NC)	3-way mixing
<b>Body rating</b>	PN 16 Nominal, 20 bar (300 psi) maximum rated pressure		
<b>Body size</b>	DN15, DN20		
<b>Flow characteristic</b>	On/Off in combination with VA-7010 actuator series On/Off in combination with VA-7040 actuator series Linear or equal percentage with VA-7450 actuator series		
<b>Service</b>	Water, glycol solutions (max 30%) for HVAC applications. Fluid Group 1 according 67/548/EEC. (proper water treatment is recommended, refer to VDI 2035)		
<b>Max. pressure drop <math>\Delta p</math></b>	200 kPa		
<b><math>Kv_s</math> and max. close-off pressure</b>	See "Ordering Data" table		
<b>Body Connections</b>	BSP Parallel (ISO 228/1, BS 2779, DIN 259) BSP taper (ISO R7/1, BS 21, DIN 2999) NPT American Standard Pipe Thread (ANSI B1.20.1) Sweat Female (ANSI B16.18)		
<b>Nominal Stroke</b>	3 mm		
<b>Connection thread to actuator</b>	M28 x 1.5		
<b>Materials</b>	Body:	Bronze Gs-CuSn5Zn5Pb5 EN1982	
	Trim:	Centrepiece: Brass UNI 5705 (P-CuZn40Pb2)	
		Locknut: Brass UNI 5705 (P-CuZn40Pb2)	
		Packing nut: Brass UNI 5705 (P-CuZn40Pb2)	
		Packing: (2) EPT 851 O-ring (Ethylene Propylene Terpolymer)	
		Stem: AISI 303 stainless steel (X10CrNiS1809)	
		Spring: AISI 302 stainless steel (X10CrNi1809)	
		Plug: EPDM EP659/75 Rubber (Ethylene Propylene Diene Terpolymer) co-moulded onto the brass disk	
<b>Leakage</b>	max 0,01% of $Kv_s$ , Class IV for ANSI FCI 70-2 and EN60534-1		
<b>Fluid Temperature Limits</b>	2...95°C		
<b>Ambient Temperature Limits</b>	2...50°C		
<b>Max. weight in g excl. packaging</b>			
	<b>DN15</b>	280	330
	<b>DN20</b>	290	420
		480	
<b>Compliance</b>	PED (Pressure Equipment Directive) 23/97/CE (Paragraph 3, comma 3) CE marking is not applicable.		

The performance specifications are nominal and conform to acceptable industry standards. For application at conditions beyond these specifications, consult the local Johnson Controls office. Johnson Controls, Inc. shall not be liable for damages resulting from misapplication or misuse of its products.



### Johnson Controls International, Inc.

Headquarters: Milwaukee, WI, USA

European Headquarters: Westendhof 8, 45143 Essen, Germany

European Factories: Lomagna (Italy), Leeuwarden (The Netherlands), Essen (Germany)

Branch Offices: Principal European Cities.  
This document is subject to change without notice

# VG4000 / VG5000 / VB-5071

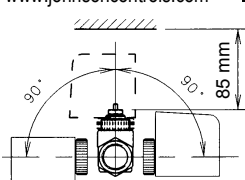

HORIZONTAL MOUNTING

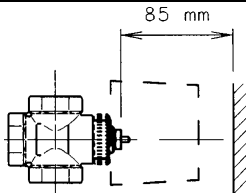

VERTICAL MOUNTING

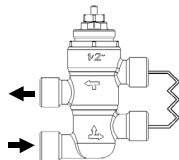

OK

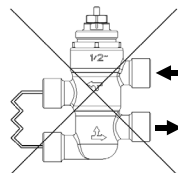

NO

These valves are primarily designed to regulate the flow of water in response to the demand of a controller in zone and terminal unit applications.

## Mounting

1. The flow must respect the direction of the arrow reported on the valve body.
2. For 3-way with built-in by-pass valves, see also sketch aside.

## Instruction for $KV_s$ adjustment

**IMPORTANT:** On VG5000 and VB-5071 models it is possible to adjust the valve  $KV_s$ . Please refer to the product bulletin "VG5000 Forged Brass Valves" for the list of field adjustable models and  $KV_s$  values.

1. Unscrew locknut A using suitable wrench.
2. Rotate trim Valve with wrench size 17 mm in the desired position required for the desired  $KV_s$  (see pertinent product bulletin).  
**ATTENTION:** Don't use hexagon "B" of packing nut for this operation.
3. Tighten locknut "A" up to indication 1 on the center-line.

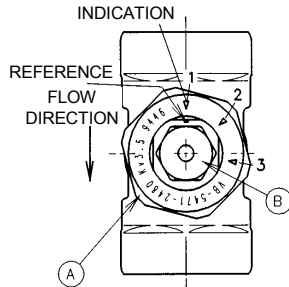

## Specifications

Models	VG4000	VG5000 / VB-5071
Body Rating	PN16	
Max working pressure	20 Mpa - 30 PSI	
Service	Water, glycol solutions (max 30%) for HVAC applications. Fluid Group 1 according 67/548/EEC. (proper water treatment is recommended, refer to VDI 2035)	
Inherent flow characteristics	Quick opening	
Fluid temperature	2 to 95°C / 35 to 203°F	
Ambient operating conditions	2 to 50°C / 35 to 122°F	
Max pressure drop	All sizes 200 kPa / 30 PSI	DN15 1/2" = 200 kPa / 30 PSI DN20 3/4" = 100 kPa / 15 PSI DN25 1" = 62 kPa / 9 PSI
Close-off pressure	2-way valves and PDT0 port on 3-way valves 340 kPa / 50 PSI PDT0 port on 3-way valves 170 kPa / 25 PSI	Please refer to the product bulletin "VG5000 Forged Brass Valves"
Compliance	PED (Pressure Equipment Directive) 23/97/CE (Paragraph 3, comma 3) CE marking is not applicable.	

## Maintenance and service

VG4000-1	Packing Nut with integral o-ring
VG5000-1	

JOHNSON  
CONTROLS

**INSTALLING VG4x7x and VG5x7x  
SWEAT CONNECTIONS VALVES**



**CAUTION**

- Not apply direct flame to the valve as indicated in Figure 1.

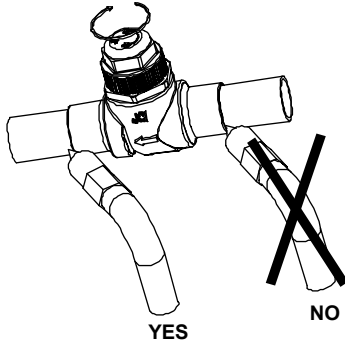

**Figure 1**

Use only lead or tin base solder with melting point below 260°C (500°F) to avoid damage to the packing and plug material.

Do not overheat the valve. Before soldering place valve manually in open position; checking that the cap is completely screwed down in the direction indicated by the arrow (See Figure 1).

30°

15

135

80

Clean ends of tubing for about 3 cm (1") to enable a good joint in a minimum time and with a practical size flame. Apply flame to tube first to transfer as much heat as possible through tube into the valve. Avoid prolonged heating of valve itself. After sweating operation wait for the valve to cool before removing the cap.

**Table 1: Ref. ANSI B16.18 – 1994 (See Figure 2)**

	1/2"	3/4"	1"
<b>Ø A</b>	16.0	22.3	28.7
<b>B</b>	12.5	19.0	23.0

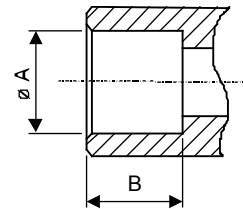

**Figure 2**

P/N 14-88211-78 Rev. B