

RA-3100-8026 Fast Running Electric Actuator

Introduction

The RA-3100 series synchronous motor-driven reversible fast running actuators are available for 3-point (floating) or with electric positioner for 0...10 V control. They feature factory calibrated pressure switches to provide specified close-off ratings.

These actuators are available in two models of 1200 N nominal thrust with 13 mm stroke for size DN 15...DN 40 and 1700 N nominal thrust with 25 mm or 42 mm stroke for size DN 50...DN 150. They are intended for use with Johnson Controls flanged valves according to maximum close-off pressure ratings specified.

A hand crank for manual operation is standard.

Factory fitted options, such as 2k Ω feedback potentiometer and auxiliary switches are available.



RA-3100 Actuator with VG8000N valve

Features and Benefits

<input type="checkbox"/> Fast Running	Under 30 seconds for full stroke
<input type="checkbox"/> Uses synchronous motor with pressure switches	Fixed close-off force Constant running time
<input type="checkbox"/> Special clamp coupler quick-fit system	Provides quick and easy mounting of the actuator on valves with slotted stem. Cuts installation costs.
<input type="checkbox"/> Models for 3-point and proportional 0...10 VDC control	Allows optimum choice of control signal
<input type="checkbox"/> Positioner with adjustable starting point, span, and direct/reverse action	Provides flexibility in application Allows easy sequencing from only one output signal
<input type="checkbox"/> Active 0...10 VDC position feedback on proportional models	Provides active signal for independent position monitoring
<input type="checkbox"/> Optional auxiliary switches and feedback potentiometer available	Provides potential free contacts for independent monitoring of the actuator's position
<input type="checkbox"/> Hand crank for manual operation as standard	Allows manual positioning independent of power supply

Ordering data

RA-31	□□	-8	□□□
Actuator Thrust & Supply Voltage			
126	1200 N 24 V, 50Hz		
226	1700 N 24 V, 50 / 60Hz		
Accessories, factory mounted			
00	None		
03	Two auxiliary switches and 2 kΩ feedback potentiometer		
41	Built-in electronic Positioner 0...10 V DC and two auxiliary Switches		

A hand crank for manual operation is standard

Ordering Procedure

The valves and actuators can be ordered separately or factory mounted. When factory mounted, please add “+M” behind the order code for the actuator.

For example:

For a 2-way valve, DN 65, k_{VS} 63, PN 16 plus actuator with electric positioner 0...10 V input, 24 VAC / 50 Hz supply, order:

Item 1 **VG82G1S1N** (valve body)
 Item 2 **RA-3141-8226** (actuator)

Alternatively, if actuator is requested to be factory mounted, order:

Item 1 **VG82G1S1N** (valve body)
 Item 2 **RA-3141-8226+M** (actuator)

Retrofit Kits

EQ-5687-7011	Two auxiliary switches and feedback 2 kΩ potentiometer
282 3703 202	Cable adapter 20 PO black EN 50262
282 3802 202	M20 x 1.5 nickel-plated brass nut

Spare parts

170 0572 040 (EQ-0572-7041)	Electronic positioner EPOS plug-in module for on site replacement
---------------------------------------	---

Actuator / Valve combinations

The RA-3100-8026 electric actuators are specifically designed to be used in conjunction with the VG8000N, VG8000H, VG8300N and VG8300H valve series. The ordering data for these valve bodies are as follows:

● VG8000N series (PN16 flanged valves)

2-way PDTC **DN 15...100**
3-way mixing **DN 15...100**
3-way diverting **DN 15...100**

● VG8300N series (PN 16 balanced pressure valves)

2-way PDTC **DN 40...150**

● VG8000H series (PN 25 flanged valves Max fluid temperature 280°C)

2-way PDTC **DN 15...100**
3-way mixing **DN 15...100**
3-way diverting **DN 15...100**

● VG8300H series (PN 25 balanced pressure valves)

2-way PDTC **DN 40...150**

Please refer to the relevant flanged valve product bulletins for complete ordering information.

Operation

3-point models

Connections	Actuator Stem
1-2	extends
1-3	retracts

Proportional models

Action Jumper	Input control signal	Actuator Stem
Direct acting (DA)	increases decreases	retracts extends
Reverse acting (RA)	increases decreases	extends retracts

Mounting instructions

When mounting the actuator on a valve, please follow the instructions below:

- It is recommended that the valves be mounted in the upright position in a conveniently accessible location. When mounted horizontally, the yoke should be fitted such that the stanchions are positioned vertically one above the other.

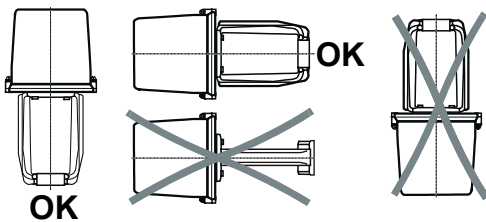

- The actuator must be protected against dripping water, which could enter the housing and damage the mechanism or motor.
- The actuator must not be covered with insulating material
- Sufficient clearance must be allowed for actuator removal (refer to the dimension drawings)
- The valve must be fitted so that the plug seats against the flow as indicated by the arrow(s) on the valve body.

Wiring instructions

- All wiring must be in accordance with local regulations and national electrical codes, and should be carried out by authorised personnel only.
- Make sure that the line power supply is in accordance with the power supply specified on the device.
- See also the instructions in paragraph "Application".

⚠ WARNING
Shock Hazard
 Disconnect the power supply before wiring connections are made to avoid personal injury.

Equipment Damage Hazard
 Make and check all wiring connections before applying power to the system. Short circuited or improperly connected wires may result in permanent damage to the unit

Wiring diagrams

3-point models

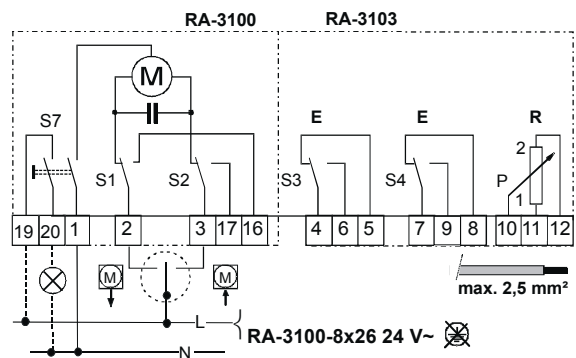

Proportional models

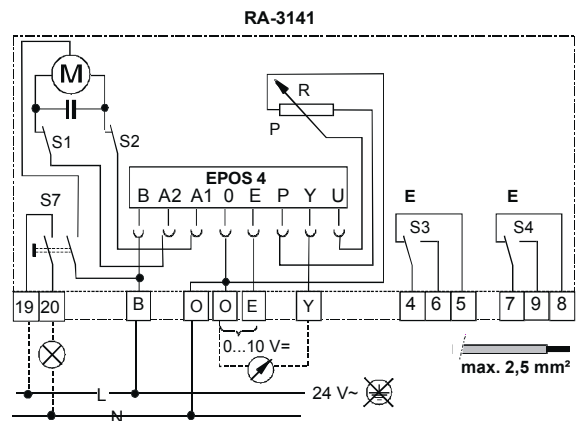

Adjustments

WARNING

Shock Hazard

The utmost care must be taken when the cover is removed (by authorised personnel only) for adjustment or inspection.

In all other cases when the cover is removed the power must be switched off.

Do not touch or attempt to connect or disconnect wires when the electrical power is on.

Switch S7

The electrical supply can be switched off manually by pressing the red button on the underside of the motor unit housing. When power is off it protrudes 5 mm, with power on, it protrudes 2 mm.

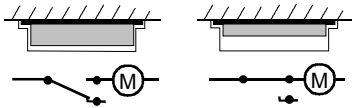

Hand crank (optional) enables manual positioning of the valve. The power supply should be switched off by means of switch S7 before the hand crank is used.

Actuators with 0...10 V DC Positioner

Models with built-in electronic positioner have a 0...10 V input. The starting point, the span and the D.A. or R.A. (Direct or Reverse Action) mode can be adjusted on the positioner.

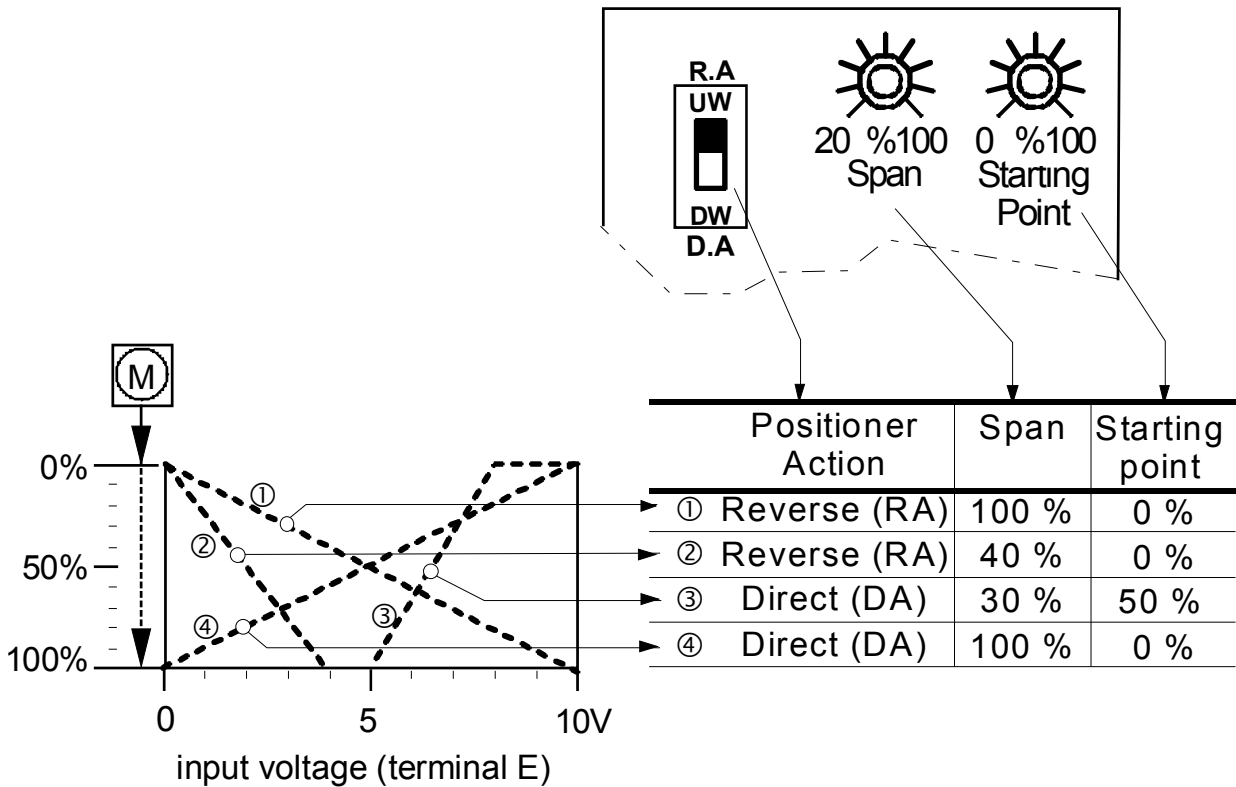

Applications

Parallel and sequenced operation of actuators

CAUTION
 Parallel connection is only possible using isolation relays. If the parallel running motors do not have separately switched power supplies one or more motors will start to cycle at the end of travel.

Actuators (24V only) with built-in positioner for controllers with 0...10V output

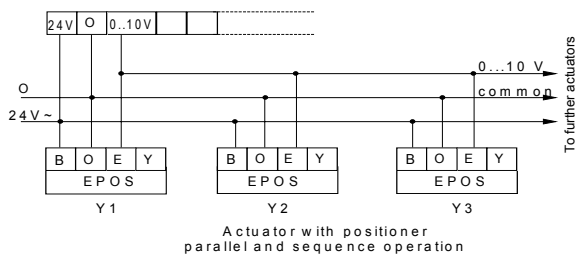

The controller output 0...10 V can operate several actuators with built-in electronic positioner EPOS. The electrical wiring for parallel and sequenced operation is identical. The sequencing and action of the actuator are individually adjustable on each positioner. Each positioner has its own adjustment for starting point between 0...10 V (0...100 %) and span between 2...10 V (20...100 %). Using the minimum adjustable span of 20 % therefore enables a maximum of 5 sequenced devices; further sequencing can be accomplished by using additional controller outputs. Each positioner can be switched for direct or reverse action.

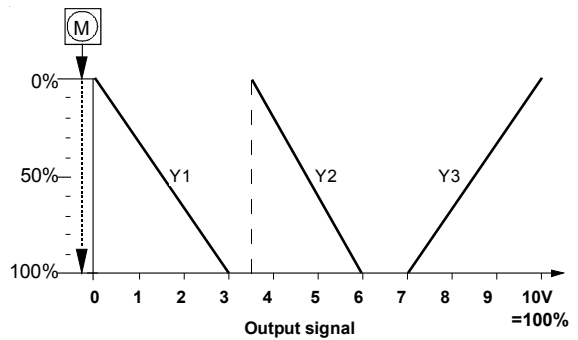

Adjustments for Y1, Y2, Y3 (example):

	starting point	span	positioner action
Y1	0 %	30 %	reverse acting
Y2	35 %	25 %	reverse acting
Y3	70 %	30 %	direct acting

Reversible actuator without positioner for incremental controller

Sequencing two actuators without positioner using limit switches

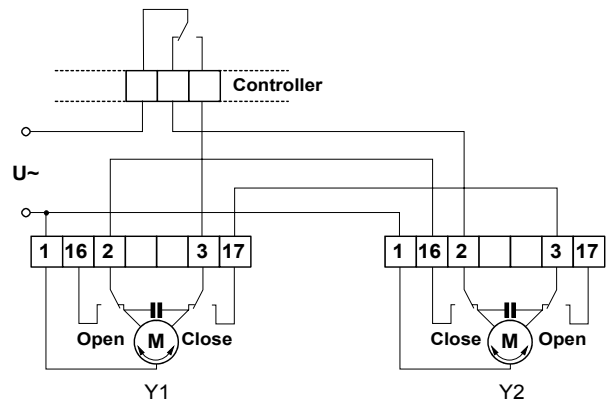

Parallel operation of actuators without positioner with synchronous motor, condenser and limit switches

Although synchronous motors have the same running speed (rate of travel) deviation in travel between motors can accumulate during starts and stops because of varying load. This deviation depends on the number of on/off cycles and is about 0.5 % per 100 cycles. By periodical switching of the actuators to end of travel (e.g. normal position) parallel-operated actuators can run reasonably synchronous.

Dimensions in mm

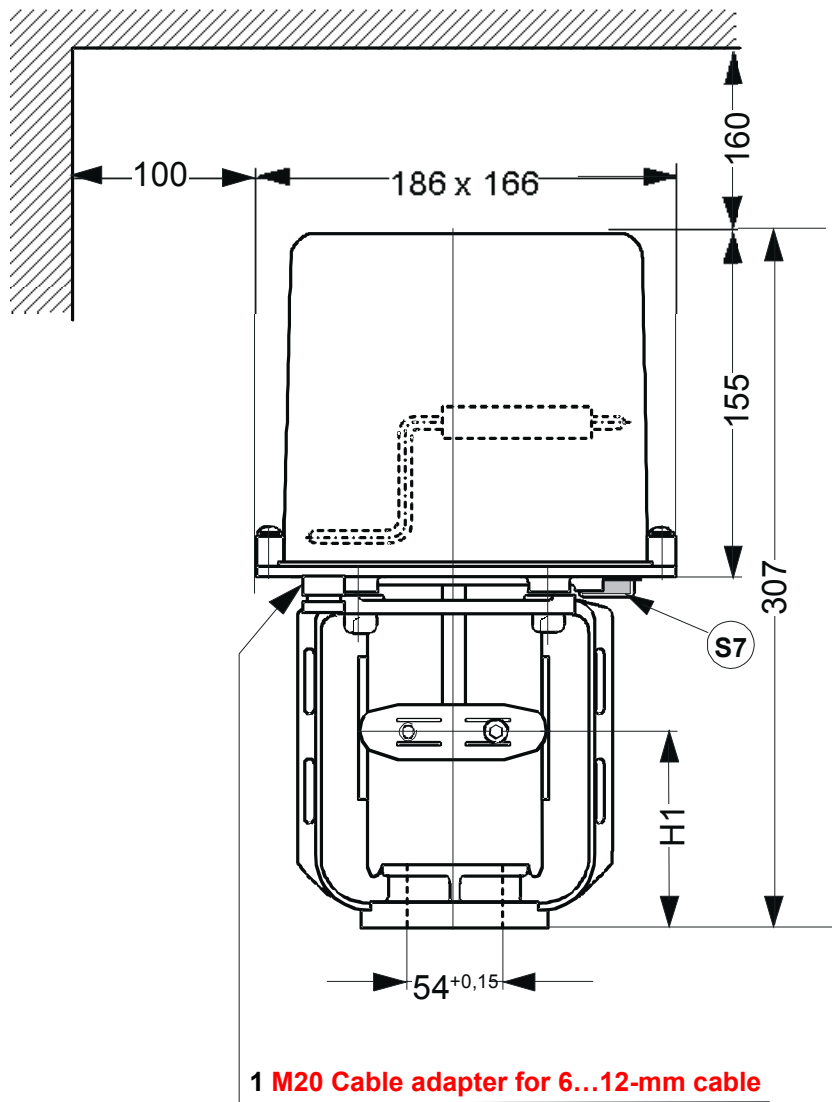

	RA-31xx -8126	RA-31xx -8226
H1	58 mm	66 mm

Notes:

Specifications

Actuator models		RA-31xx-....	
		-8126	-8226
Associated valve series and body sizes	VG8000N DN 15...40	VG8000N DN 50...100	
	VG8000H DN 15...40	VG8000H DN 50...100	
	VG8300N & H DN 40 With balanced pressure	VG8300N & H DN 50...150 With balanced pressure	
Type of motor		Synchronous, Reversible	
Action / Control	<ul style="list-style-type: none"> · 3-point · 3-point with 5(3) A / 250 VAC auxiliary switches and 2kΩ or 135Ω feedback potentiometer · Proportional with built-in 0...10 V electronic positioner (input impedance 5.6 kΩ) and with 5(3) A / 250 VAC auxiliary switches 		
Hand crank		Standard	
Supply voltage and frequency*)	24 VAC \pm 10%, 50 Hz	24 VAC \pm 10%, 50 (60) Hz	
Power consumption (with positioner)	12 VA (14 VA)	26 VA (28 VA)	
Continuous running time	50%	50%	
Nominal force	1200 N ⁽⁺¹⁰⁰⁾	1700 N ⁽⁺¹⁰⁰⁾	
Nominal stroke	13 mm	25 mm valve stroke	42 mm
Nominal running speed			
At valve sizes	DN 15...DN 40	DN 50...DN 80	DN 100...DN 150
At 50 Hz	23.4 sec. (1.8 s/mm)	17.5 sec (0.7 s/mm)	29.4 sec (0.7 s/mm)
At 60 Hz		15 sec (0.6 s/mm)	25.2 sec (0.6 s/mm)
Enclosure Protection	IP 54		
Materials:			
Stem	Stainless steel (DIN Material spec. No. 1.4305)		
Motor unit housing and Yoke	Die cast aluminium		
Operation and Storage Conditions	-10...60 °C (-10...50 °C with electronic positioner) R.H. 10...90 %, non condensing		
Electrical Connection	Threaded terminal for 2.5 mm ² wire gauge		
Conduit adapter	1 x M20 cable adapter +1 M20 blanking plug		
Net weight	4 kg		
Approvals	European Directives: EMC (89 / 336 / EEC) LVD (73 / 23 / EEC)		

*) For other supply voltage and frequency, please contact your Johnson Controls supplier.

The performance specifications are nominal and conform to acceptable industry standards. For application at conditions beyond these specifications, consult the local Johnson Controls office. Johnson Controls, Inc. are not liable for damages resulting from misapplication or misuse of its products.



Johnson Controls International, Inc.

Headquarters:
European Customer Service Center:
European Factories:
Branch Offices

Milwaukee, Wisconsin, USA
Westendhof 3, D-45143 Essen, Germany
Essen (Germany), Leeuwarden (The Netherlands) and Lomagna (Italy)
Principal European Cities.

: Printed in Germany