

M9216

3-Point Electric Spring-Return Damper-Actuator

Application

This Johnson Controls electric spring-return damper-actuator has been specially developed for the motorised operation of safety (anti-icing) air dampers in air conditioning systems, smoke evacuation and sealing dampers. When the control signal is applied the actuator drives the damper to the operational position while evenly tensioning the integrated spring.

After a power failure the spring immediately brings the damper to the safe position. Manual operation is automatically cancelled when the actuator is in electrical operation.

Key Features

- 3-point control
- Screw terminal connections
- Universal adapter for:
 - Round shafts from 10...20 mm dia.
 - Square shafts from 10...16 mm
- Low noise level
- Direction of rotation selection
- Angle-of-rotation limiting
- Manual control by pushbutton
- 2 floating auxiliary switches
- Power saving at end stops
- Customising available



Type/Specifications/Technical data

M9216-AGA-1	Damper actuator 24 VAC
M9216-AGC-1	Damper actuator 24 VAC with 2 adjustable auxiliary switches
M9216-AGE-1	Damper actuator 24 VAC/VDC with feedback potentiometer 1K Ω
M9216-AGD-1	Damper actuator 24 VAC/VDC with feedback potentiometer 140 Ω
M9216-AGF-1	Damper actuator 24 VAC/VDC with feedback potentiometer 2K Ω

Actuators	Units	M9216-AG.-1
Drive torque	Nm	16
Damper area approx.	m ²	3.0
Running time -motor	sec	90...120
-spring	sec	10
Power supply	V	24 VAC/VDC
Frequency	Hz	50-60
Power consumption:		
- operating	W	10
- at end stops	W	4
For wire gauge	VA / I max	18.0 / 8 A @ 2 msec
Weight	Kg	2.7
Control signal	Y1	3-point
Position signal	U	Potentiometer
Angle-of-rotation/limits		0°...30° und 90°...60°
Auxiliary switch rating		3 (1.5) Amp 24 V
Range of adjustment		5°...85° fully variable
Expected life time approx.		60'000 rotations
Noise level		50 dB (A)
Protection class		II
Enclosure		IP 40
Ambient temperature range		-20...50°C
Ambient humidity		5...95% rH non-condensing
Maintenance		Maintenance-free
Standards		The actuators meet CE requirements

Subject to design modifications without notice

Wiring diagram

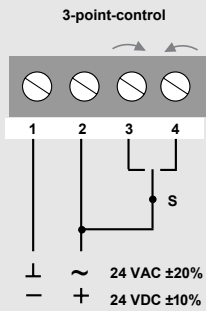

When changing the direction of rotation several times in quick succession, allow a delay of 1.0 s after each change.

Dimensions (mm)

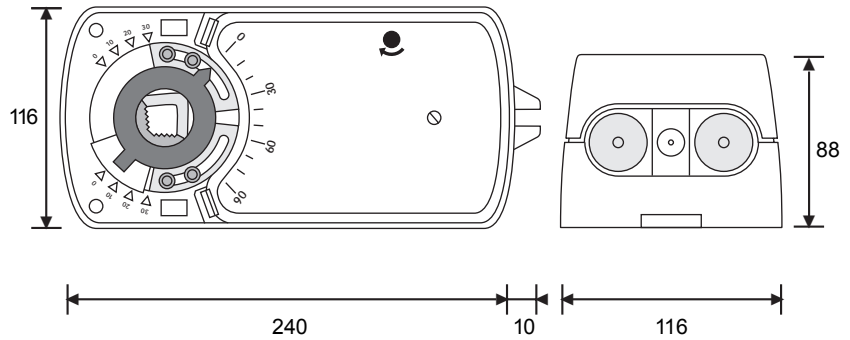

Parallel connection

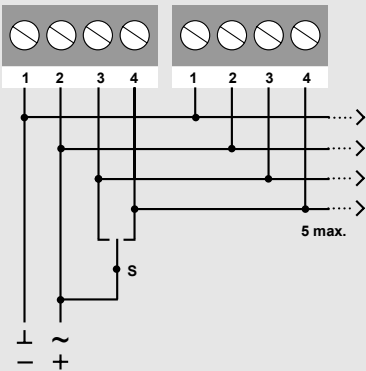

Changing direction of rotation

The direction of rotation can be changed by simply reversing the adapter sleeve.

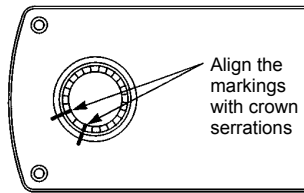

**Factory setting/
Clockwise rotation.**

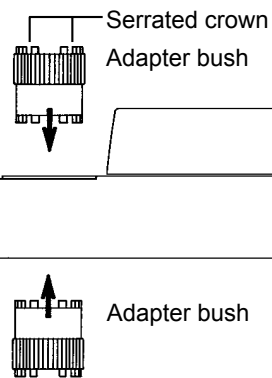

Auxiliary switches (S)

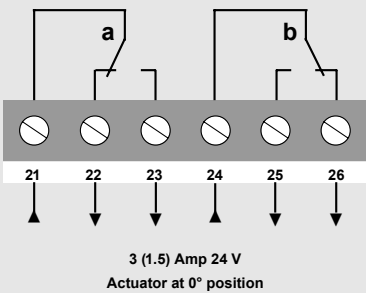

Auxiliary switch adjustment

Factory setting
Switch a at 10°
Switch b at 80°

To adjust the auxiliary switch contact positions, turn manually as required.

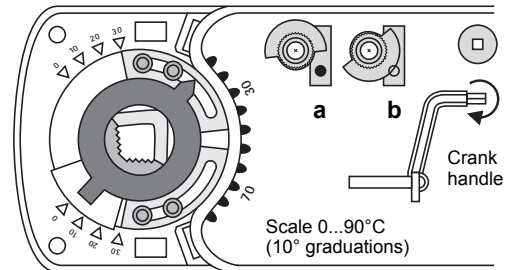

Potentiometer (P)

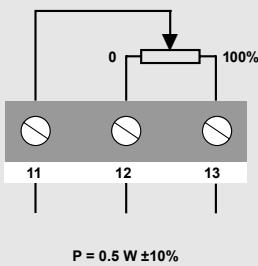

Angle-of-rotation limiting

The angle of rotation/working range of 90° can be reduced by up to 30° from each end position by means of Segment 1 and 2.

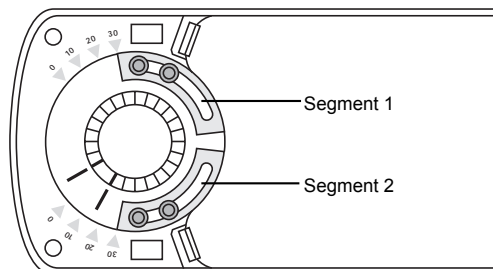

For details of installation and commissioning see Service and Data Information (SDI)

The performance specifications are nominal and conform to acceptable industrial standards. For application at conditions beyond these specifications, consult the local Johnson Controls office. Johnson Controls Incorporated shall not be liable for damages resulting from misapplication or misuse of its products

M9216

2-Point Electric Spring-Return Damper-Actuator (110 VAC)

Application

This Johnson Controls electric spring-return damper-actuator has been specially developed for the motorised operation of safety (anti-icing) air dampers in air conditioning systems, smoke evacuation and sealing dampers. When the control signal is applied the actuator drives the damper to the operational position while evenly tensioning the integrated spring.

After a power failure the spring immediately brings the damper to the safe position. Manual operation is automatically cancelled when the actuator is in electrical operation.

Key Features

- 2-point control
- Screw terminal connections
- Universal adapter for:
 - Round shafts from 10...20 mm dia.
 - Square shafts from 10...16 mm
- Low noise level
- Direction of rotation selection
- Angle-of-rotation limiting
- Manual control by pushbutton
- 2 floating auxiliary switches
- Power saving at end stops
- Customising available



Type/Specifications/Technical data

M9216-BAA-1	Damper actuator 110 VAC
M9216-BAC-1	Damper actuator 110 VAC with 2 adjustable auxiliary switches

Actuators	Units	M9216-BA.-1
Drive torque	Nm	16
Damper area approx.	m ²	3.0
Running time -motor	sec	90...120
-spring	sec	10
Power supply	V	24 VAC/VDC
Frequency	Hz	50-60
Power consumption:		
- operating	W	8
- at end stops	W	4.5
For wire gauge	VA / I max	18.0 / 0.3 A @ 2 msec
Weight	Kg	2.7
Control signal	Y1	2-point
Angle-of-rotation/limits		0°...30° und 90°...60°
Auxiliary switch rating		3 (1.5) Amp 230 V
Range of adjustment		5°...85° fully variable
Expected life time approx.		60'000 rotations
Noise level		50 dB (A)
Protection class		II
Enclosure		IP 40
Ambient temperature range		-20...50°C
Ambient humidity		5...95% rH non-condensing
Maintenance		Maintenance-free
Standards		The actuators meet CE requirements

Subject to design modifications without notice

Wiring diagram

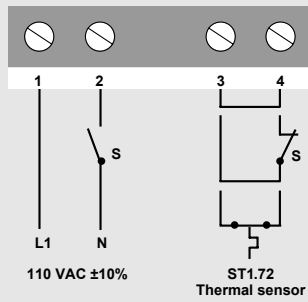

Dimensions (mm)

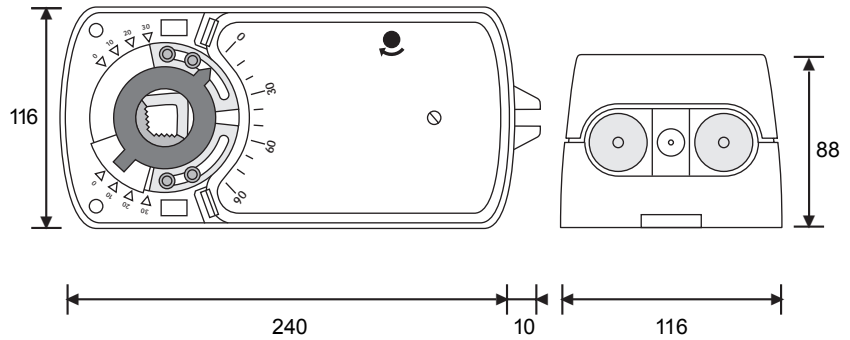

Parallel connection

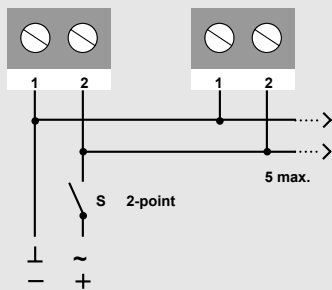

Changing direction of rotation

The direction of rotation can be changed by simply reversing the adapter sleeve.

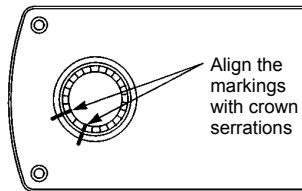

**Factory setting/
Clockwise rotation.**

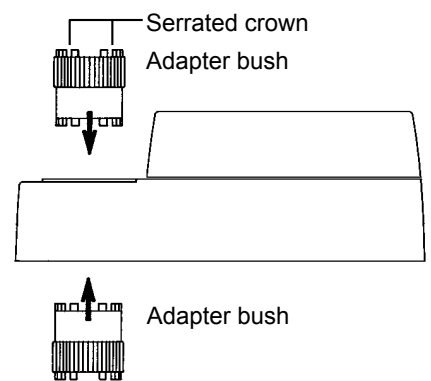

Auxiliary switches (S)

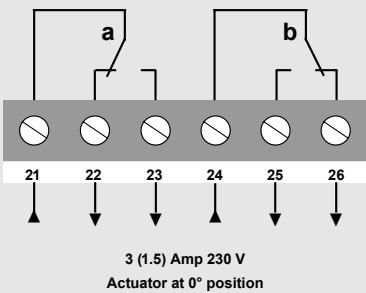

Auxiliary switch adjustment

Factory setting
Switch a at 10°
Switch b at 80°

To adjust the auxiliary switch contact positions, turn manually as required.

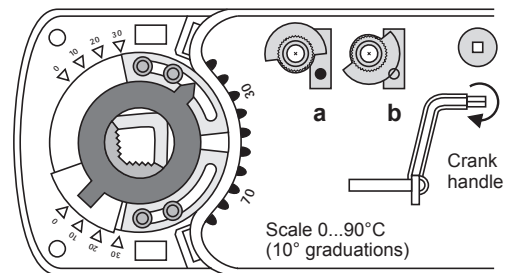

Angle-of-rotation limiting

The angle of rotation/working range of 90° can be reduced by up to 30° from each end position by means of Segment 1 and 2.

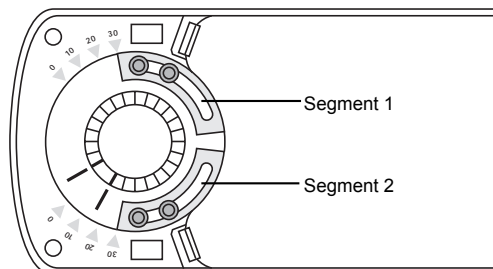

For details of installation and commissioning see Service and Data Information (SDI)

The performance specifications are nominal and conform to acceptable industrial standards. For application at conditions beyond these specifications, consult the local Johnson Controls office. Johnson Controls Incorporated shall not be liable for damages resulting from misapplication or misuse of its products

**JOHNSON
CONTROLS**
Johnson Controls International, Inc.
Headquarters:
European Customer Service Centre:
European Factories:
Branch Offices

Milwaukee, Wisconsin, USA
Westendhof 3, D-45143 Essen, Germany
Essen (Germany), Leeuwarden (The Netherlands) and Lomagna (Italy)
Principal European Cities.

Printed in Germany

M9216

2-Point Electric Spring-Return Damper-Actuator

Application

This Johnson Controls electric spring-return damper-actuator has been specially developed for the motorised operation of safety (anti-icing) air dampers in air conditioning systems, smoke evacuation and sealing dampers. When the control signal is applied the actuator drives the damper to the operational position while evenly tensioning the integrated spring.

After a power failure the spring immediately brings the damper to the safe position. Manual operation is automatically cancelled when the actuator is in electrical operation.

Key Features

- 2-point control
- Direct connection of thermal sensor ST1.72 for duct interior temperature monitoring approx. 72°C
- Screw terminal connections
- Universal adapter for:
 - Round shafts from 10...20 mm dia.
 - Square shafts from 10...16 mm
- Direction of rotation selection
- Angle-of-rotation limiting
- Manual control by pushbutton
- 2 floating auxiliary switches
- Power saving at end stops



Type/Specifications/Technical data

M9216-BGA-1	Damper actuator 24 VAC/VDC
M9216-BGC-1	Damper actuator 24 VAC/VDC with 2 adjustable auxiliary switches
M9216-BDA-1	Damper actuator 230 VAC
M9216-BDC-1	Damper actuator 230 VAC with 2 adjustable auxiliary switches

Actuators	Units	M9216-BG.-1	M9216-BD.-1
Drive torque	Nm	16	16
Damper area approx.	m ²	3.0	3.0
Running time: - motor	sec	90...120	90...120
- spring	sec	10	10
Power supply	V	24 VAC/VDC	230 VAC
Frequency	Hz	50-60	50-60
Power consumption			
- operating	W	10	8
- at end stops	W	4	4.5
For wire gauge	VA / I max	18.0 / 4 A @ 2 msec	13.0 / 0.3 A @ 2 msec
Weight	Kg	2.7	2.9
Angle of rotation/Working range		90° (93° mech.)	
Control signals		2-point	
Range of adjustment		5°...85° fully variable	
Angle of rotation/limits		0°...30° and 90°...60°	
Auxiliary switch rating		3 (1.5) Amp 230 V	
Service life approx.		60'000 cycles	
Noise level		50 dB (A)	
Protection class		II	
Enclosure		IP 40	
Ambient temperature range		-20...50°C	
Ambient humidity		5...95% rH non-condensing	
Maintenance		Maintenance free	
Standard		The actuators meet CE requirements	

Subject to design modifications without notice

**Wiring diagram
M9216-BG.-1/M9216-BD.-1**

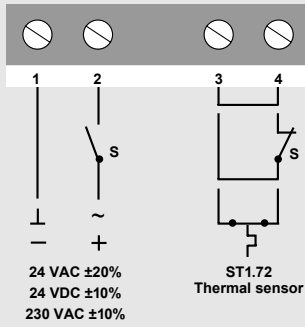

Dimensions (mm)

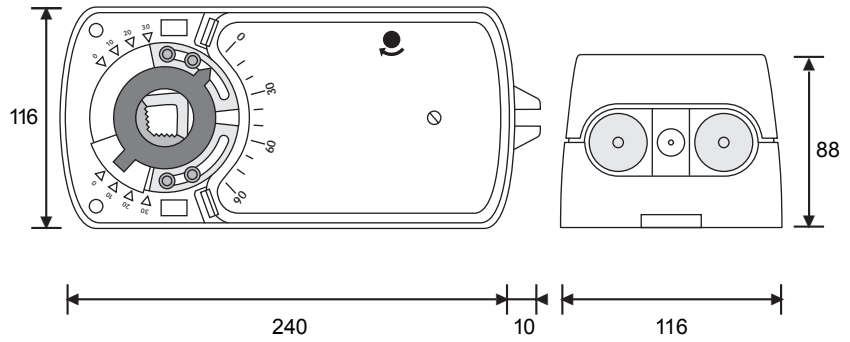

Parallel connection

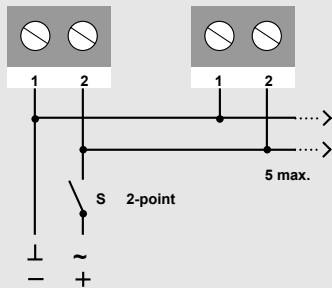

Changing the direction of rotation

The direction of rotation can be changed by simply reversing the adapter sleeve.

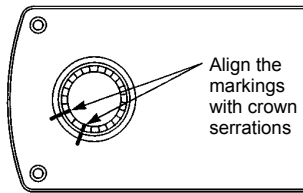

**Factory setting/
Clockwise rotation.**

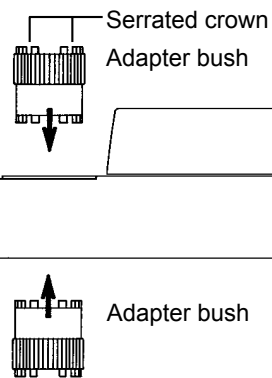

Auxiliary switches (S)

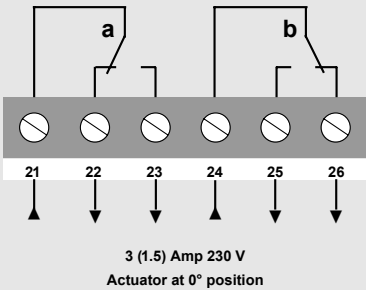

Auxiliary switch adjustment

Factory setting
Switch a at 10°
Switch b at 80°

To adjust the auxiliary switch contact positions, turn manually as required.

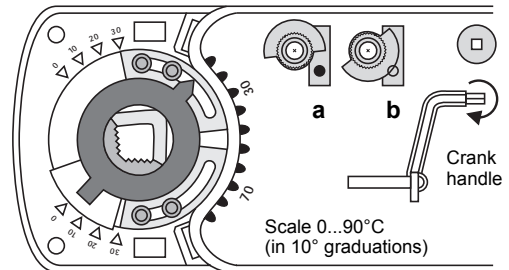

Angle-of-rotation

The angle of rotation/working range of 90° can be reduced by up to 30° from each end position by adjusting segment 1 and 2.

Angle-of-rotation limiting

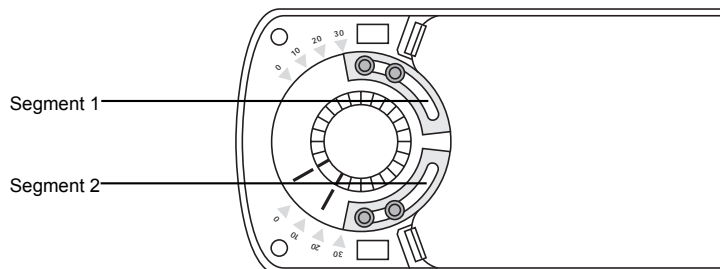

For details of installation and commissioning see Service and Data Information (SDI)

The performance specifications are nominal and conform to acceptable industrial standards. For application at conditions beyond these specifications, consult the local Johnson Controls office. Johnson Controls Incorporated shall not be liable for damages resulting from misapplication or misuse of its products

M9216

Proportional Electric Spring-Return Damper-Actuator

Application

This Johnson Controls electric spring-return damper-actuator has been specially developed for the motorised operation of safety (anti-icing) air dampers in air conditioning systems, smoke evacuation and sealing dampers. When the control signal is applied the actuator drives the damper to the operational position while evenly tensioning the integrated spring.

After a power failure the spring immediately brings the damper to the safe position. Manual operation is automatically cancelled when the actuator is in electrical operation.

Key Features

- 0...10 VDC or 0...20 mA control
- Up to 5 actuators in parallel
- Screw terminal connections
- Universal adapter for:
 - Round shafts from 10...20 mm dia.
 - Square shafts from 10...16 mm
- Low noise level
- Reversible
- Angle-of-rotation limiting
- Manual control by pushbutton
- 2 floating auxiliary switches
- Power saving at end stops



Type/Specifications/Technical data

M9216-HGA-1R	Damper actuator 24 VAC
M9216-HGC-1R	Damper actuator 24 VAC with 2 adjustable auxiliary switches

Actuators	Units	M9216-HG.-1R
Drive torque	Nm	16
Damper area approx.	m ²	3
Running time -motor	sec	90...120
-spring	sec	10
Power supply	V	24 VAC/VDC
Frequency	Hz	50-60
Power consumption:		
- operating	W	10.0
- at end stops	W	4.0
For wire gauge	VA / I max	12.0 / 6 A @ 2 msec
Weight	Kg	2.7
Control signal	Y1	0...10 VDC
Control signal	Y2	0...20 mA
Position signal	U	0...10 VDC
Angle-of-rotation:	- working range	90° (93° mech.)
	- limiting	0°...30° and 90°...60°
Auxiliary switch rating		3 (1.5) Amp 230 V
Expected life time approx.		60'000 cycles
Noise level		50 dB (A)
Protection class		II
Enclosure		IP 40
Ambient temperature range		-20...50°C
Ambient humidity		5...95% rH non-condensing
Maintenance		Maintenance-free
Standards		The actuators meet CE requirements

Subject to design modifications without notice

Wiring diagram

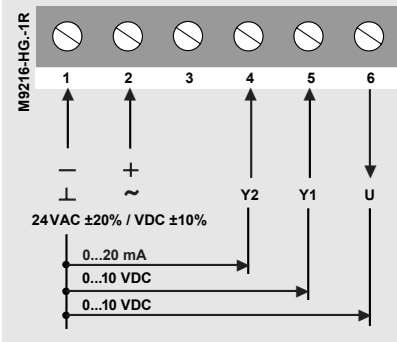

Adjusting the control signals

Control signal Y1	0...10 VDC
Input resistance	$R_i > 200 \text{ k}\Omega$
Control signal Y2	0...20 mA
Input resistance	$R_i = 388\Omega$
Position signal U	0...10 VDC
Load resistance	$> 10 \text{ k}\Omega$

Microswitch d

Deactivated



Activated



Pot. for signal p

Pot. O

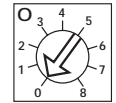

Pot. S

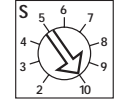

The self-adapting feature helps you to adjust the actuator to a restricted angle-of-rotation. The feature is activated when microswitch **d** is in the ON position.

Parallel connection

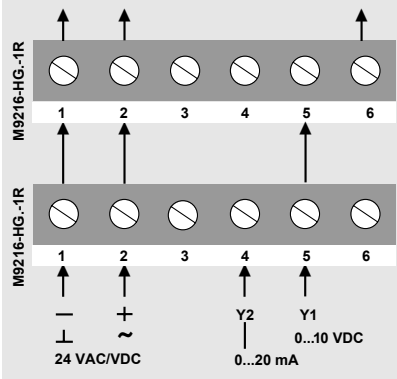

When M9216-HG.-1R actuators are to be operated in parallel, the output signal $U = 0...10 \text{ VDC}$ (Terminal 6) of the master actuator must be connected to Terminal 5 of the next slave actuator, etc.

Note:

Up to 5 actuators can be operated in parallel.

Remote positioner

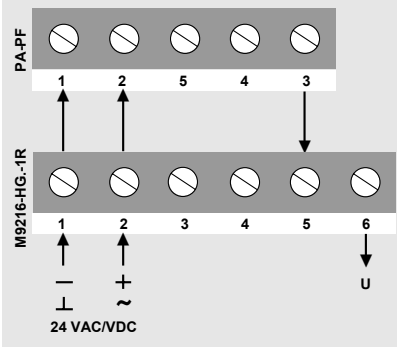

M9216-HG.-1R actuators can also be controlled by means of a Johnson Controls 0...10 VDC remote positioner.

Note:

Up to 5 actuators can be operated in parallel.

Override control

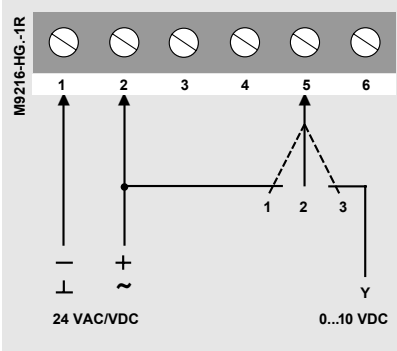

Override control of M9216-HG.-1R actuators can be provided with the circuitry shown opposite.

Switch position:

- 1 = Actuator runs at 10 V
- 2 = Actuator runs at 0 V
- 3 = Automatic control

Dimensions (mm)

M9000-PA in surface-mounted housing

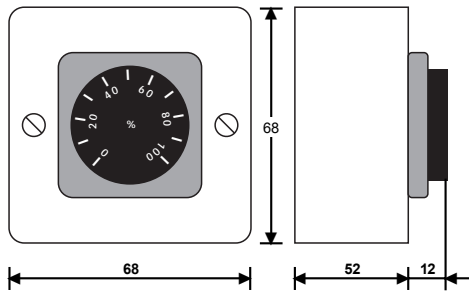

M9000-PF for flush mounting

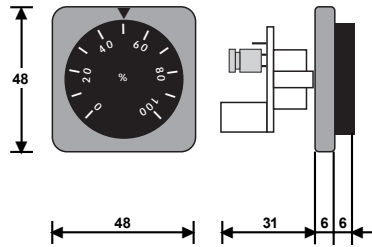

Drilling template

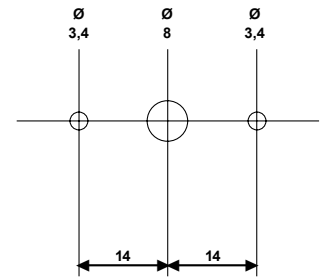

Designations/Specifications/Technical data

M9000-PA 0...100% Remote positioner for surface mounting
 M9000-PF 0...100% Remote positioner for flush mounting

For actuators	Type	M9216-HG.-1R
Power supply	V	24 VAC/VDC ±20%
Frequency	Hz	50-60
Output signal U	U	0(2)...10 VDC
Output rating		for up to 5 actuators
Control signal Y1	V	0(2)...10 VDC

Wiring diagram

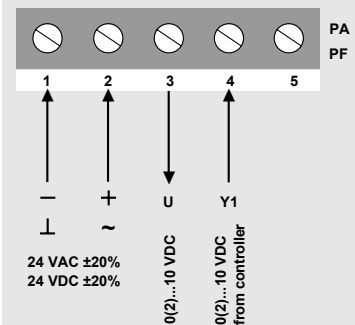

Output signal matching

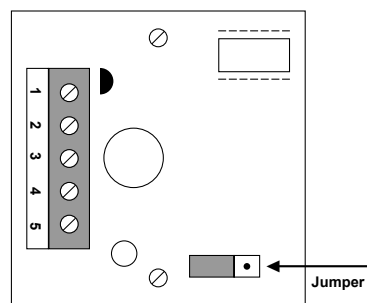

The output signal 0...10 VDC or 2...10 VDC is proportional to 0...100% rotation of the adjuster knob.

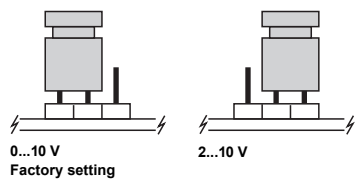

for manual control

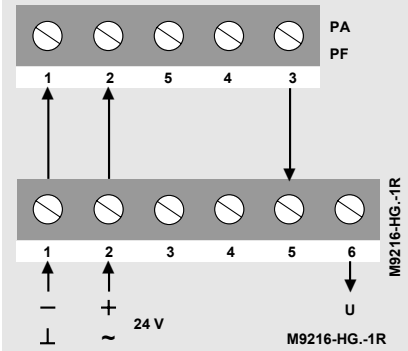

Angle-of-rotation limiting

0...100%

20...80%

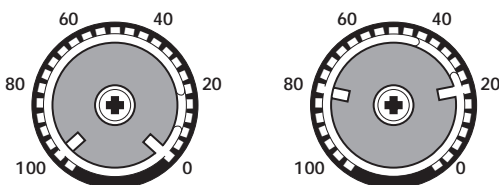

The adjuster knob can be removed by pulling it out of the front plate. Inside the knob the mechanical limiting of the angle-of-rotation can be adjusted by moving the stop springs.

Factory setting 0...100%.

for minimum limiting

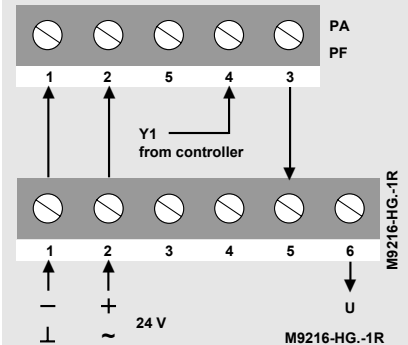

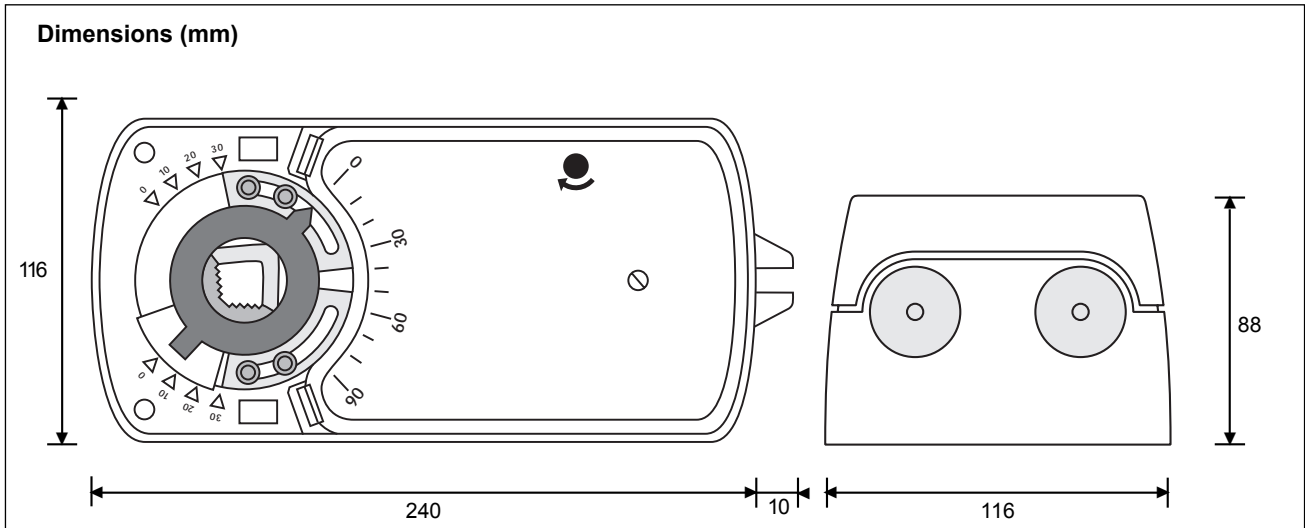

Direction of rotation

In order to reverse the direction of rotation, move microswitch 2 to the ON position - the action of the output signal will also be changed in the process.

Plug (c) must never be reversed otherwise the motor will not function correctly.

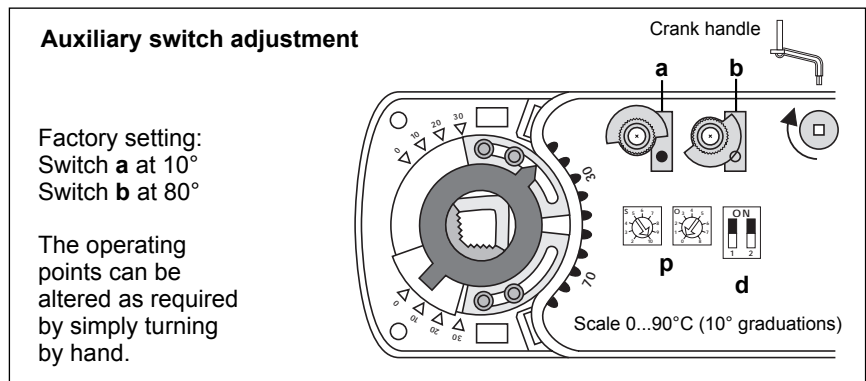
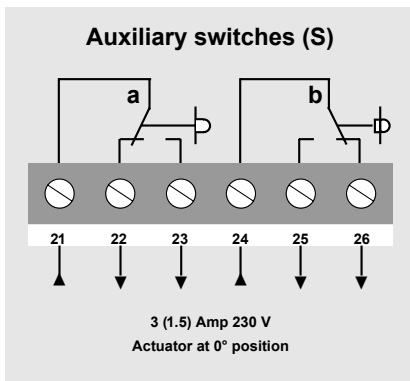
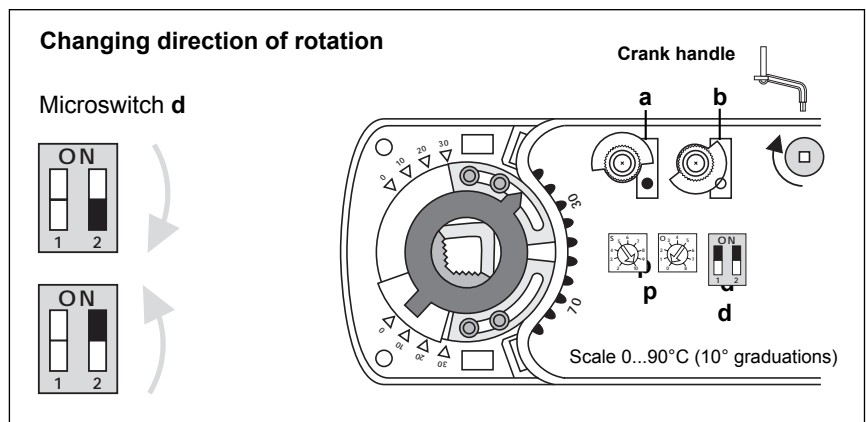

Angle-of-rotation

The angle of rotation/working range of 90° can be reduced by up to 30° from each end position by means of Segments 1 and 2.

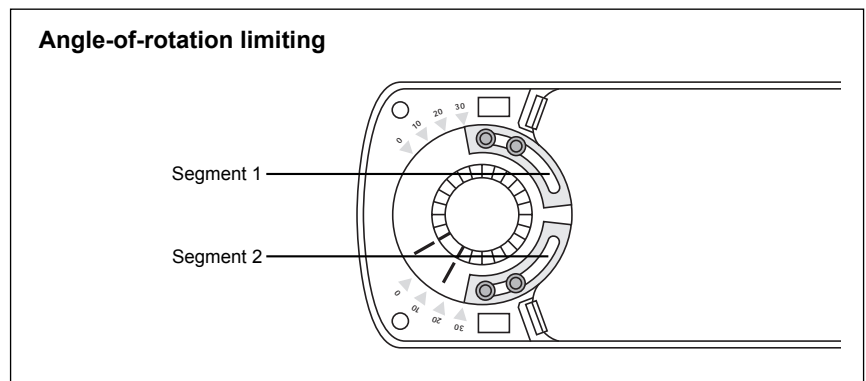

The performance specifications are nominal and conform to acceptable industrial standards. For application at conditions beyond these specifications, consult the local Johnson Controls office. Johnson Controls Incorporated shall not liable for damages resulting from misapplication or misuse of its products