

# Application Note G41-015

## “Single loop + limit, 1 Output”

### Series SC-9100-8GEN

## Overview

**G41-015** 1 device, AHU, humidifying or de-humidifying, universal 0...10V input

- AI1** analog input 0/10 V, Room R.H.
- AI2** analog input 0/10 V, Supply R.H.
- DI1** digital alarm input.
- DI2** digital mode input, Clock
- AO1.1 or TR1/TR2** Output 0..10 V or 3-Point

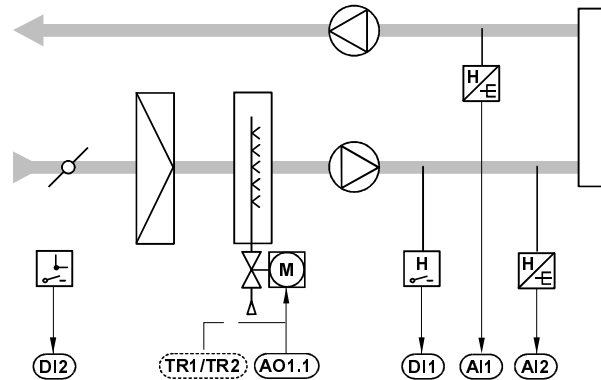

## Control Functions

### Control Block Diagrams

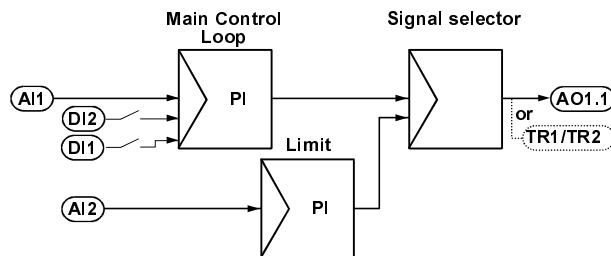

### Functional Diagrams

#### Low Limit Control

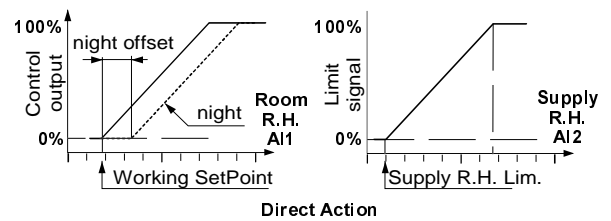

#### High Limit Control (default)

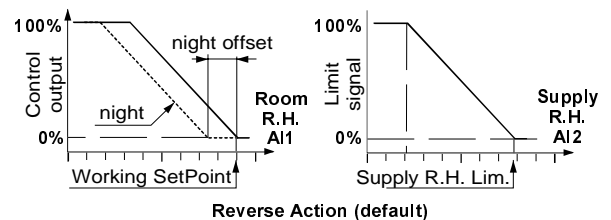

## Description

<b>Master control loop</b>	The room R.H. on input <b>AI1</b> is compared with the working setpoint of the main PI-control loop which sends the 0...100% information to the signal selector
<b>Limit loop</b>	The supply R.H. on input <b>AI2</b> is compared with the supply limit setpoint of the limit PI-control loop which sends the 0...100% information to the signal selector
<b>Signal selector</b>	selects the minimum of the outputs of the main control loop and the limit control loop and sends the 0...10V (AO1.1) or 3-point (TR1/TR2) output to a controlled device (e.g. a vapor valve)  Examples of configuration: <ul style="list-style-type: none"> <li>• <b>High limit control:</b> Main control loop and limit loop must be set as reverse acting (negative proportional bands); e.g. a vapor valve and a high humidity supply limit</li> <li>• <b>Low limit control:</b> Both loops must be set as direct acting (positive proportional band); e.g. a cooling coil for de-humidification and a low humidity supply limit.</li> </ul>
<b>Alarm contact</b>	Contact closure on the alarm input <b>DI1</b> forces the output of the controller to a value of 0 or 100% depending on what is required for the application (configurable)
<b>Mode contact (day/night)</b>	Contact closure on the input <b>DI2</b> activates the preset night offset of the working setpoint.

## List of Materials

The code numbers mentioned hereafter are only indications. To get the complete code numbers of the specific product related to your application, refer to the J.C. products catalogs.

I/O code	Description	Type / Ordering code	Comments
	DDC Controller	SC-9100-8GEN	
<b>AI1</b>	Room R.H. , 0...10 V	HT-8020, HT-8052, W99	0...10 V
<b>AI2</b>	Supply R.H. , 0...10 V	HT-8020, HT-8052, W99	0...10 V
<b>DI1</b>	Alarm contact, e.g. from:	270XT, A19, A25CN, HC12, P48, P33, etc.	N.O. contact
<b>DI2</b>	Mode contact, e.g. from:	Y27C, etc.	N.O. contact
<b>AO1.1 or TR1/TR2</b>	Valve and actuator  Staging relay	VG7000 and actuator VG8000 and actuator, etc. SR9100	Actuator for 0...10 V or 3 point  0...10 V input, 2 relay outputs, 250 V~, 10(5) A.

# Connections

## Connection Diagram

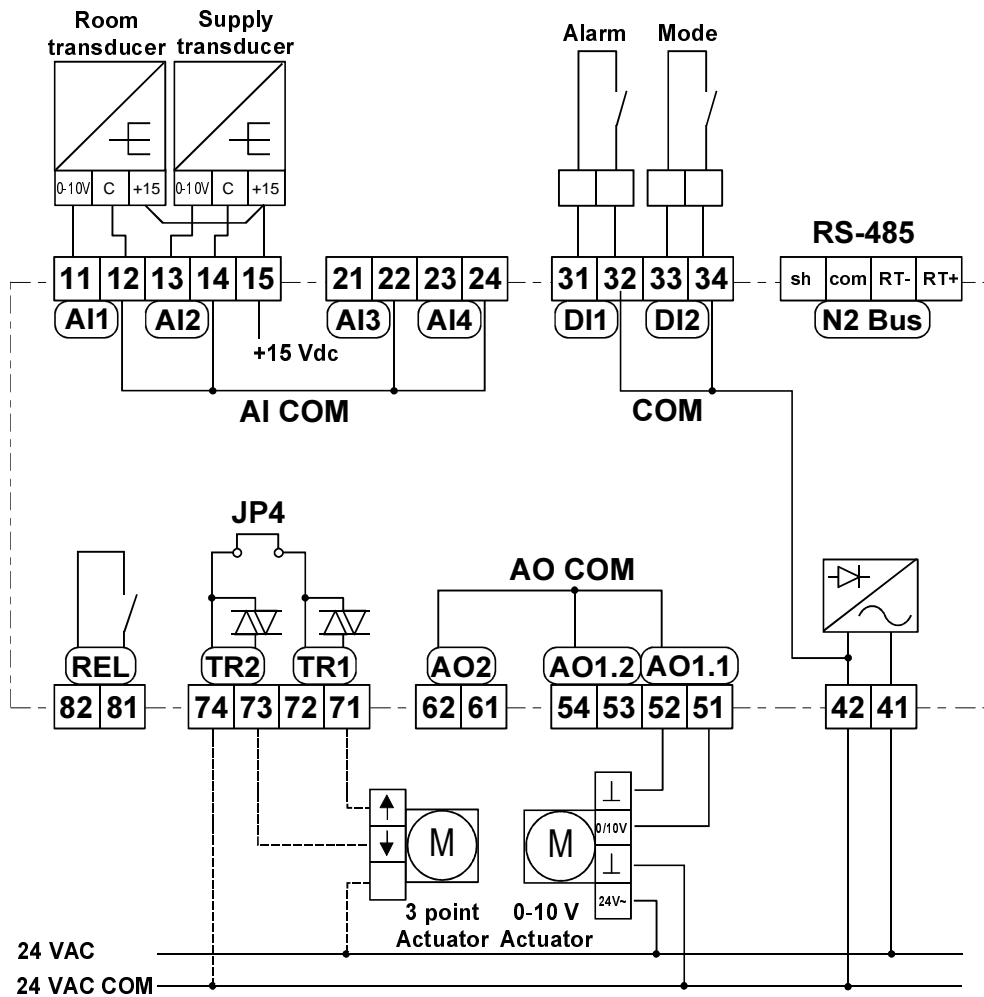

Note: 0...10VDC and 3-point outputs are driven from the same control module in parallel.

### Wiring Instructions

For wiring follow the instructions below  
 All wiring must be in accordance with local regulations and national rules

**⚠ WARNING**

When wiring and servicing make sure that:

- the electric supply to the controller and auxiliary devices is switched off to avoid possible damage to the equipment, personal injury or shock.
- you do not touch or attempt to connect or disconnect wires when electric power is on.

Note:

*These controllers are designed for use as an operating control. When an operating control failure would result in personal injury or loss of property, it is the responsibility of the installer to wire a separate backup control (e.g. a freeze protection thermostat) in order not to use the controller as an operating and safety device.*

### Wiring recommendation

I/O	No. of wires	Wire $\phi$ in mm <sup>2</sup>	Max. cable length
Power supply	2	1.5	100 m.
AI1, AI2	3	1	75 m.
DI1, DI2	2	0.75	150 m.
AO1.1	2	1	75 m.
TR1/TR2	3	1	75 m.

## Operation and Commissioning

### User Interface Description

The frontpanel of the SC-9100 controller consists of a two-line LCD display with 16 characters per line and 4 operation keys.:

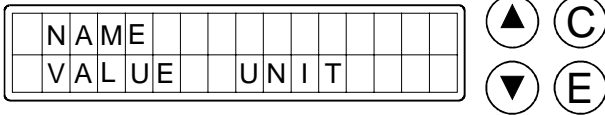

The keys have following function:

- ▲ / ▼ to scroll up/down in a set of possible items or increase/decrease a value
- Ⓔ to confirm a selection or an operation
- Ⓒ to decrease the access level or to cancel a selection or an operation.

The display is back-lighted when the controller is supplied with power.

The controller has three levels of operation:

**Level 1 / User Level:** The user can display and modify the user points.

**Level 2 / Commissioning Level:** The user can display and modify the commissioning points. It is accessible by pushing ▲ during 10 s.

**Level 3 / JC Level:** After entering a password the operator has access to personalization features and to all items of the controller.

### Application selection

When first installed, the SC-9100 displays **“Please wait”** and then **“Enter Access Key to Level 2”**

Select the required application by following key sequence:

- ▲ during 10 s. Application  
Not. Sel.
- Ⓔ to enter modification mode. The first line blinks to indicate this mode.
- ▲ / ▼ as many times as necessary to select the required application.: Application 14  
G41 015

- Ⓔ Confirms your choice. A sequence of messages will appear. The last message indicates the chosen application, now without blinking first line

- ⒸⒺ Leaves the Commissioning Level (Level 2) to return to the user level (Level 1). Abandon Level 2  
C = NO, E = YES

- ▲ displays the welcome window or one of the user points Temp Setpt  
22 21

### Displaying points

At power up with application selected or after application selection as described above the controller will display the welcome window.

- ▲ / ▼ to scroll through the list of user points. The point name will be displayed in the first line. The second line displays the actual value with engineering unit: Room R.H.  
m 45,5%

- ▲ during 10 s. will enter Level 2 (commissioning level), where the commissioning points can be displayed in the same way as described above.

- ⒸⒺ Leaves the Commissioning Level (Level 2) to return to the user level (Level 1). Abandon Level 2  
C = NO, E = YES

- Note: if no key is pressed during 1 hour, then the commissioning level will be automatically abandoned and the SC will display the welcome window.

**Modifying analog and digital outputs**

The outputs, as listed in the “List of Points”, can be modified, when they are forced in manual mode:

▲ / ▼ Select a user point or after entering the commissioning level (▲ 10 s.) a commissioning point, of which the output value can be modified.

ⓔ Enter the manual mode. An “m” starts blinking in front of the displayed output value:

**Control Output.**  
m 45,0%

ⓔ Start the modification operation. The point name will blink.

▲ / ▼ Increases/decreases the output value.

ⓔ Confirms the modification operation. Only now the physical output takes the manual value set by the operator. The point name stops blinking, but the “m” remains blinking as the point remains in manual mode.

Or

ⓐ Cancels the modification operation. The output is not modified and the point name stops blinking, but the “m” remains blinking as the point remains in manual mode.

ⓐ Leaves the manual mode. The “m” in front of the displayed output value disappears.

ⓐⓔ Leaves the Commissioning Level (Level 2) to return to the user level (Level 1). **Abandon Level 2**  
C = NO, E = YES

**Modifying other parameters (setpoints, etc.)**

The points, as listed in the “List of Points”, can be modified as follows:

▲ / ▼ Select a user point or after entering the commissioning level (▲ 10 s.) a commissioning point, that can be modified.

ⓔ Start the modification operation. The point name will blink.

▲ / ▼ Increases/decreases the displayed value.

ⓔ Confirms the modification operation. The point name stops blinking.

Or

ⓐ Cancels the modification operation. The point value is not modified and the point name stops blinking.

ⓐⓔ Leaves the Commissioning Level (Level 2) to return to the user level (Level 1). **Abandon Level 2**  
C = NO, E = YES

## List of points

### Application G41-015

#### User points, Level 1

Point name	Description	Range + Unit	Modifiable	Default Value	I/O
<b>Room R.H.</b>	Range can be modified in level 2	0...100 %	No		<b>AI1</b>
<b>Working Setpoint</b>	= Local SetPoint + Night Offset	%	No		
<b>Local SetPoint</b>		-1000..+1000	Yes	50	
<b>Supply R.H.</b>	Range can be modified in level 2	0...100 %	No		<b>AI2</b>
<b>Supply WSP limit</b>	To be set to the required supply R.H.limit	-1000..+1000	Yes	80	
<b>Control Output</b>	Indicates the output of the controller for both 0-10 V and 3-point	0...100 %	Yes		<b>AO1.1 TR1/2</b>
<b>Alarm Status</b>	At contact closure the output is automatically forced to 0% or 100% depending on the setting (see Level 2, " <b>Alrm.Forc.Outp.</b> ").	Off="Normal" On="Alarm!"	No		<b>DI1</b>
<b>Mode</b>	At contact closure the setpoint is automatically shifted by the value of the Night Offset.	Off="Day" On="Night"	No		<b>DI2</b>

#### Commissioning points, Level 2

Point name	Description	Range + Unit	Modifiable	Default Value	User Value
<b>Prop. Band PB1</b>	PB of main control loop Negative value for reverse acting and positive value direct acting. Note: Sign of PB1 and PB2 should be the same.	-1000..+1000	Yes	-20	
<b>Integr. Time TI1</b>	Ti = 0 means P-control. Don't set Ti = 0 for 3-point output.	0...10 Rp/m	Yes	0	
<b>Night Offset</b>	Neg. or pos. offset to the working setpoint, activated through DI2.	-1000..+1000	Yes	0	
<b>Prop. Band PB2</b>	PB of limit loop. See also Proportional band PB1.	-1000..+1000	Yes	-20	
<b>Integr. Time TI2</b>	Integral time of limit loop	0...10 Rp/m	Yes	0	
<b>PAT Time Base (3-point)</b>	Approx. equal to the full stroke time of the 3-point actuator.	30...200 sec.	Yes	60	
<b>Alrm.Forc.Outp.</b>	To be set to 0 or 100% depending on what is required for the application (has to be set only if DI1 connected).	Off="0 %" or On="100 %"	Yes	Off	
<b>Hi Range Input1</b>	High limit for the range of AI1	-1000..+1000	Yes	100	
<b>Lo Range Input1</b>	Low limit for the range of AI1	-1000..+1000	Yes	0	
<b>Hi Range Input2</b>	High limit for the range of AI2	-1000..+1000	Yes	100	
<b>Lo Range Input2</b>	Low limit for the range of AI2	-1000..+1000	Yes	0	

The performance specifications are nominal and conform to acceptable industry standards. For application at conditions beyond these specifications, consult the local Johnson Controls office. Johnson Controls, Inc. shall not be liable for damages resulting from misapplication or misuse of its products.

Johnson Controls International, Inc.  
Headquarters Milwaukee, WI, USA  
European headquarters Essen, Germany

Branch Offices in Principal Cities

Printed in Germany