

Series P255MM/ML

Single/Dual Pressure Input Condenser Fan Speed Controllers For Three Phase Motors (incl. built-in RFI suppression filter)

Introduction

These controllers are designed for speed variation of 3-phase motors, especially for fan speed control on air cooled condensers.

Head pressure control of a refrigeration system, through speed variation of the fan on an air-cooled condenser, results in optimum performance throughout the year.

Using a pressure transducer as the input device to the fan speed controller, gives the most direct and fastest response to pressure variations in the refrigerant system. The controller varies the supply voltage to the motor from 30% to at least 96% over the proportional band using the phase cutting principle. Motors that will be controlled by the P255 should not draw more than 5 A per phase.

The controller used for dual pressure input varies the fan speed by directly sensing the pressure changes of two separate refrigerant circuits. Each pressure transducer can be separately adjusted at a setpoint between 8 to 42 bar. The controller selects the input with the greatest cooling demand to control the fan speed. The transducers can be used in non-corrosive refrigerant systems.



**P255MM/ML
Condenser Fan Speed Controller**

Feature and Benefits

<input type="checkbox"/> Condenser pressure control by fan speed variation.	Optimum condenser pressure control all the year round.
<input type="checkbox"/> Pressure input.	Direct and fast response to pressure variations.
<input type="checkbox"/> Dual input possibility.	Can be used on condensers with two separate refrigerant circuits.
<input type="checkbox"/> Transducers with proven reliability.	More than half a million in use today.
<input type="checkbox"/> Easy accessible setpoint screw.	Setpoint easy adjustable. For use on various refrigerants.
<input type="checkbox"/> Built-in suppression filter.	The control meets the electro magnetic compatibility requirements of the 89/336/EEC directive.
<input type="checkbox"/> Minimum speed or cut-off selection.	Selection to keep the fan running on minimum speed or to switch it off.
<input type="checkbox"/> Adjustable minimum speed or cut-off. Adjustable maximum speed limit. Proportional band adjustment.	Maximum flexibility to adjust cooling capacity and/or to get the best motor performance.
<input type="checkbox"/> Contact input to force output to max. or off.	Control interrupt possibility.
<input type="checkbox"/> Allows connection in both "Star" and "Delta" configurations.	3 wire motor connection for both "Star" and "Delta" connection.
<input type="checkbox"/> Motor speed action can be reversed by interchanging only two wires.	Easy change over from direct to reverse control action
<input type="checkbox"/> Adjustable hysteresis in cut-off mode.	Easy motor start by adjustable start voltage.
<input type="checkbox"/> IP54 enclosure for electronic module.	Can be mounted outdoor.
<input type="checkbox"/> Cosφ motor adjustment.	Optimum control and motor performance.

Electric motor selection

Care must be taken when selecting an electric motor as the controller uses the phase cutting principle for variation of motor speed. This will cause additional heat generation in the stator (motor winding) and the rotor of the motor, especially at medium speed.

At medium speed the current to the motor will be at its highest level whereas the cooling of the motor has already substantially decreased. Motors that are designed to handle this extra heat generation are preferred. The use of thermal motor winding protection switches is advised. Often (depending on the total application conditions) a class F motor should be used to handle the temperature increase. Motors with lower temperature classification might be interrupted by the temperature protection switches, which are embedded in the motor windings. Finally, the motor should have bearings that provide sufficient lubrication at lower RPM and possibly increased shaft temperatures.

It is recommended to confirm with the electric motor manufacturer, that the motor can be used with a controller, using the phase cutting principle for speed variation. You can also provide a copy of this P255 product data sheet to the motor manufacturer/supplier for review.

Note

At lower speeds (between 50% and 75% of rpm mentioned on the motor data plate), depending on motortype and load, the max. current can become higher than I nominal of the motor. In case the max. current increases above 5 Amp. the max. allowed ambient temperature will become lower as indicated in the diagram (see fig. 1).

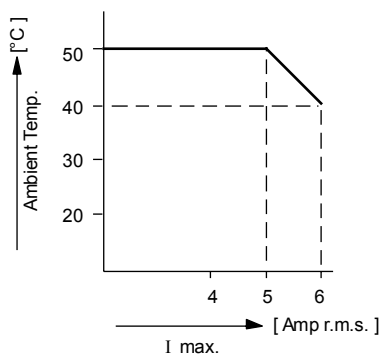

Fig. 1

Note

The P255MM/ML is intended to control equipment under normal operating conditions. Where failure or malfunction of the P255MM/ML could lead to an abnormal operating condition that could cause personal injury or damage to the equipment or other property, other devices (limit or safety controls) or systems (alarm or supervisory systems) intended to warn of or protect against failure or malfunction of the P255MM/ML must be incorporated into and maintained as part of the control system.

Description

The P255 consists of an electronic module type P38AD and a pressure transducer type P35AC.

The P38AD can be used for single or dual pressure input. For dual input a separate P35AC pressure transducer must be ordered (see type number selection table). In the case of dual input the controller selects the input with the greatest cooling demand to control the fan speed.

There are three pressure ranges:

8 to 14 bar
14 to 24 bar
22 to 42 bar

Installation

Mount the electronic module in a vertical position. The electronic module is provided with spacers to create at least 10 mm distance between the mounting surface and the heatsink. For proper air-circulation there should be a clearance around the controller of at least 50 mm. When mounted inside a cabinet, holes for air circulation should be provided. If the P255 cannot be mounted vertically, additional limitations apply. The maximum allowable current will be 3.5 A instead of 5 A or the maximum allow-able ambient temperature is reduced to 35°C instead of 50°C. The transducers can be installed in any convenient location, provided that the ambient conditions are suitable for IP20 enclosure.

Enclosed mounting bracket can be used.

Note

For style 50 pressure connections two copper seal rings (one spare) are delivered with the control. Each time the pressure connection is removed this seal ring has to be replaced.

Wiring motor

The motor can be wired in Star or Delta. To meet the EMC directive shielded cable has to be used for motor wiring in case the distance between controller and motor is more than 2 meters. If the distance is less than 2 meters it is allowed to use non-shielded cable. (see fig. 2).

Non shielded cable may be used if the control and motor are mounted in one frame.

Both sides of the shield have to be connected. To prevent stray current, the two earth connections of the controller, the motor earth connection as well as the cable shield, all have to be connected to one earthing pole (see fig. 2).

More motors can be wired in parallel, provided that the total current will not exceed 5 A rms.

EMC

The controller does have a built-in suppression filter and meets all required EC directives. Please note that when two or more EMC compliant components are built together the total system may not be compliant. To make the total system compliant is the responsibility of the producer

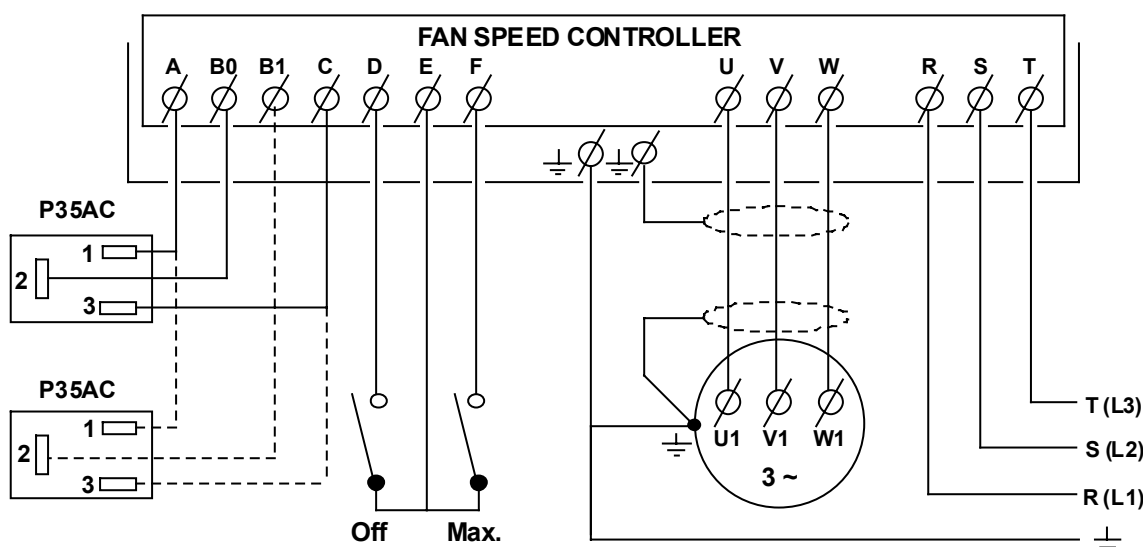

Fig. 2

Wiring pressure transducer(s)

(see fig.2)

There is low voltage (12 V) on wiring between transducer(s) and electronic module.

Enclosed quick connector plug(s) can be used to connect wires to the transducer(s).

! Caution

The enclosed quick connector plug(s) is especially designed (special terminal numbering) for this control and should not be used for other purposes. Take care to connect the correct wires when the original connector is replaced by a non Johnson Controls type.

Control action (direct/reverse)

The transducer wiring as shown in fig. 2 is for direct action (output voltage increases at increasing pressure). If reverse action is desired, this can be obtained by interchanging wires at terminals A and C of the electronic module.

Max. speed / fan off

A potential free contact can be connected to the P255 to force the output to maximum (output \geq 96% of supply voltage) or to switch the fan off (see fig. 2).

Terminal E is the common. If E is connected to F the fan goes to max. speed. If E is connected to D the fan is switched off.

Measuring

For measuring amps or volts values a true rms meter should be used.

! Caution

The P255 is not equipped with a power switch. Therefore an additional switch to isolate the device should be used in the power supply wiring to the P255.

For motor protection the use of thermal motor winding protection switches is preferred. If a thermal/ current overload relay is used the max. current (between 50% and 75% of the speed) should be measured to set the overload relay. A larger difference between I nom. and I max. results in an insufficient motor protection.

Fuses

Controller damage, caused by too high load, will be prevented /limited by the built-in 10A glass fuses. In case of malfunctioning of the controller these fuses should be checked first.

For protection of the main power wiring external 400V NEOZED or 500V DIAZET fuses can be used. The required fuse amperage depends on the used wiring. See below table.

1 mm ²	6 Amp
1.5 mm ²	10 Amp
2.5 mm ²	16 Amp

Selection 50/60 Hz (see fig.4)

The control will be delivered for use on 50 Hz supply frequency. For 60 Hz selection the selector switch position must be changed to 60 Hz.

Adjustments

The electronic module P38AD gives a control characteristic according to fig. 3. The control characteristic is affected by the load and the supply voltage.

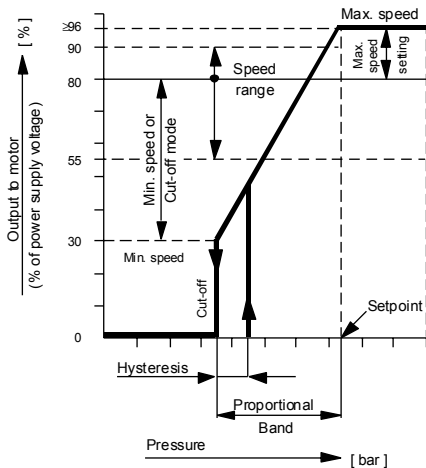

Fig.3 Factory adjusted characteristic

Adjustable settings: (see Fig. 4 and 6)

- Setpoint 8 to 14 ,14 to 24 or 22 to 42 bar
- Speed range 55 to 90% of supply voltage
- Max. speed 55 to $\geq 96\%$ of supply voltage
- Min. speed 30 to 90% of supply voltage
- Cut-off 30 to 90% of supply voltage
- Prop. band 0.5 to 4 bar (8 to 14 bar range)
1 to 6 bar (14 to 24 bar range)
1 to 8 bar (22 to 42 bar range)
- Hysteresis 5 to 70% of adj. prop. band
- Cos ϕ 0.6 to 1

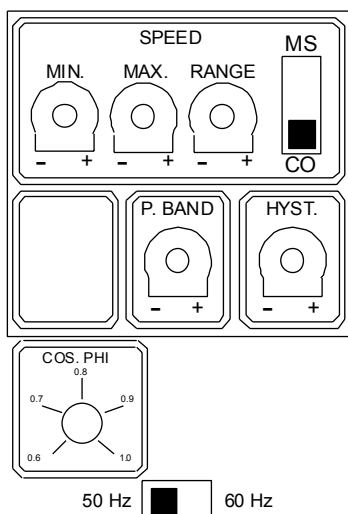

Fig.4

Factory settings

- Setpoint range 8 to 14 bar - 10 bar
range 14 to 24 bar - 16 bar
range 22 to 42 bar - 30 bar
- Speed range 80%
- Max. speed $\geq 96\%$
- Cut-off 30%
- Prop. band range 8 to 14 bar - 4 bar
range 14 to 24 bar - 6 bar
range 22 to 42 bar - 8 bar
- Hysteresis 5%
- Cos ϕ 0.8
- MS/CO switch position CO
- 50/60 Hz switch position 50 Hz

The controller will be delivered with these settings..

Setpoint

The pressure setpoint (point A) at which the control delivers maximum output can be adjusted by the range screw R (fig. 5) on the pressure transducer.

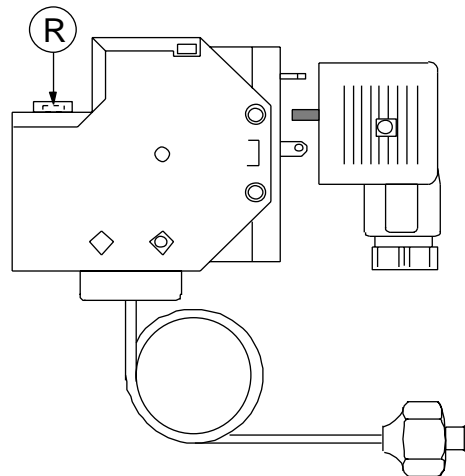

Fig. 5

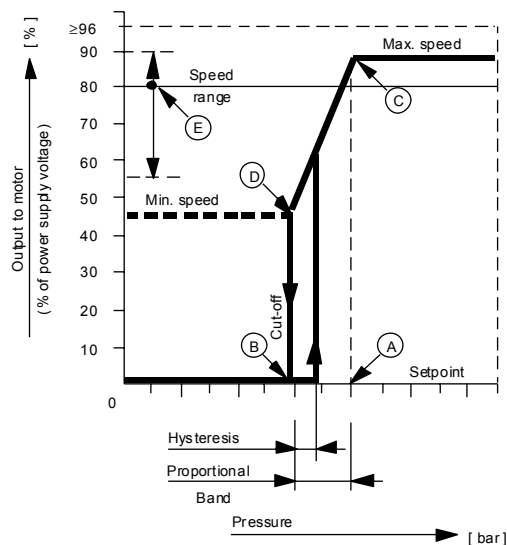

Fig. 6

Maximum speed limit

It is possible to adjust a maximum speed limit (point C). This means that the output to the motor will not increase above the adjusted setting. The maximum speed limit can be adjusted with potentiometer "MAX." inside the electronic module (see fig. 4). The maximum output voltage to the motor is adjustable from the adjusted speed range line up to $\geq 96\%$ of the power supply voltage.

Minimum speed

The minimum speed voltage setting (point D), to prevent fan speed reduction below desirable levels, can be adjusted from 30% of the power supply voltage up to the adjusted speed range line by means of potentiometer "MIN." inside the electronic module and selector switch MS/CO set to minimum speed mode MS (see fig. 4).

Speed range line

The max. speed adjustment is independent from the min. speed adjustment. To prevent that the min. speed is set to a higher value than max. speed (no output any more) the "speed range line" is introduced. This (imaginary) line divides the output characteristic into an upper part and lower part.

The maximum speed can be adjusted in the upper part (from $\geq 96\%$ down to the adjusted speed range value). The minimum speed/cut-off can be adjusted in the lower part (from 30% up to the adjusted speed range value). The speed range line (point E) can be adjusted with the speed "RANGE" potentiometer (see fig. 4) from 55% to 90% of the power supply voltage.

Cut-off mode

In the cut-off mode the output to the motor will drop to zero if the pressure decreases below point B. The fan stops. The cut-off can be adjusted from 30% of the power supply voltage up to the adjusted speed range line by means of potentiometer "MIN." inside the electronic module and the selector switch MS/CO set to cut-off mode CO (see fig. 4).

Proportional band

The proportional band is the difference between the pressure at which the output is 0 V (point B) or the minimum speed voltage (point D) and the pressure at setpoint (point A). The proportional band is adjustable with potentiometer "P-BAND" inside the electronic module. (see fig. 4)

Hysteresis

A running fan can be controlled to a low speed. Sometimes it gives trouble starting at this low speed. Therefore it is possible to adjust the hysteresis which means the motor starts at a higher voltage. The hysteresis can be adjusted by potentiometer "HYST." between 5% and 70% of the adjusted proportional band (see fig. 4).

Cos ϕ

On the motor data plate the cos ϕ of the motor is indicated. To get the most optimal control the "COSPHI" potmeter (see fig. 4) must be set to this value. If cos ϕ is not known the potmeter can be set to 0.8

Repair and replacement

Repair is not possible. In case of an improperly functioning control, please check with your nearest supplier. When contacting the supplier for a replacement you should state the type-model number of the control. This number can be found on the data plate.

Type number selection and replacement table

Order nr.	Range (bar)	Element style	Supply voltage	Transducer type	See Fig.	Electronic module type
P255ML-9200	14 to 24	47	230 V - 3 phase	P35AC-9200	13B	P38AD-9101
P255MM-9100	14 to 24	45A	400 V - 3 phase	P35AC-9106	13A	P38AD-9100
P255MM-9101	8 to 14	45A	400 V - 3 phase	P35AC-9105	13A	P38AD-9100
P255MM-9200	14 to 24	47	400 V - 3 phase	P35AC-9200	13B	P38AD-9100
P255MM-9201	8 to 14	47	400 V - 3 phase	P35AC-9201	13B	P38AD-9100
P255MM-9500	14 to 24	50	400 V - 3 phase	P35AC-9506	13A	P38AD-9100
P255MM-9501	8 to 14	50	400 V - 3 phase	P35AC-9505	13A	P38AD-9100
P255MM-9503	22 to 42	50	400 V - 3 phase	P35AC-9511	13C	P38AD-9100
P255MM-9600	14 to 24	13	400 V - 3 phase	P35AC-9604	13A	P38AD-9100
P255MM-9601	8 to 14	13	400 V - 3 phase	P35AC-9603	13A	P38AD-9100

note: 1 bar = 100 kPa ≈ 14.5 psi

All models are delivered with a single pressure transducer. A second pressure transducer can be ordered. For type number see type number selection table.

Pressure connections

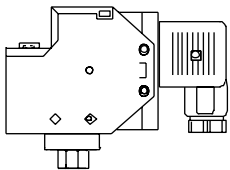

Fig. 7

Style 47 direct mount
7/16 - 20 UNF female
(incl. valve depressor)

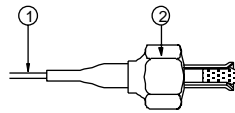

Fig. 8

Style 45A (incl. valve depressor mounted into capillary flare section)

1. 90 cm capillary.

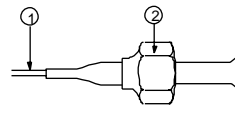

Fig. 9

Style 13 (without valve depressor)

2. 7/16 - 20 UNF flare nut.

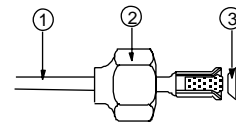

Fig. 10

Style 50 (incl. valve depressor mounted into machined flare)
3. copper seal ring

- 1 Mounting hole \varnothing 4 mm
- 2 Extruded 6-32 UNC thread
- 3 Mounting hole for P35AC \varnothing 4 mm

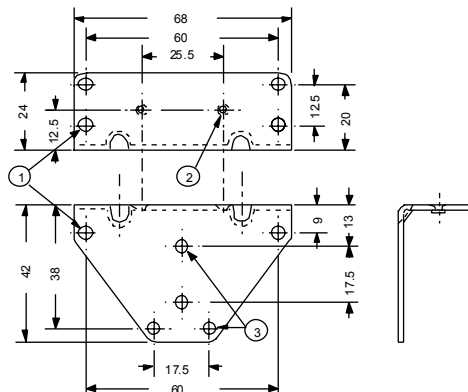

Fig. 11
Mounting Bracket 210-25

Dimensions (mm)

P38AD

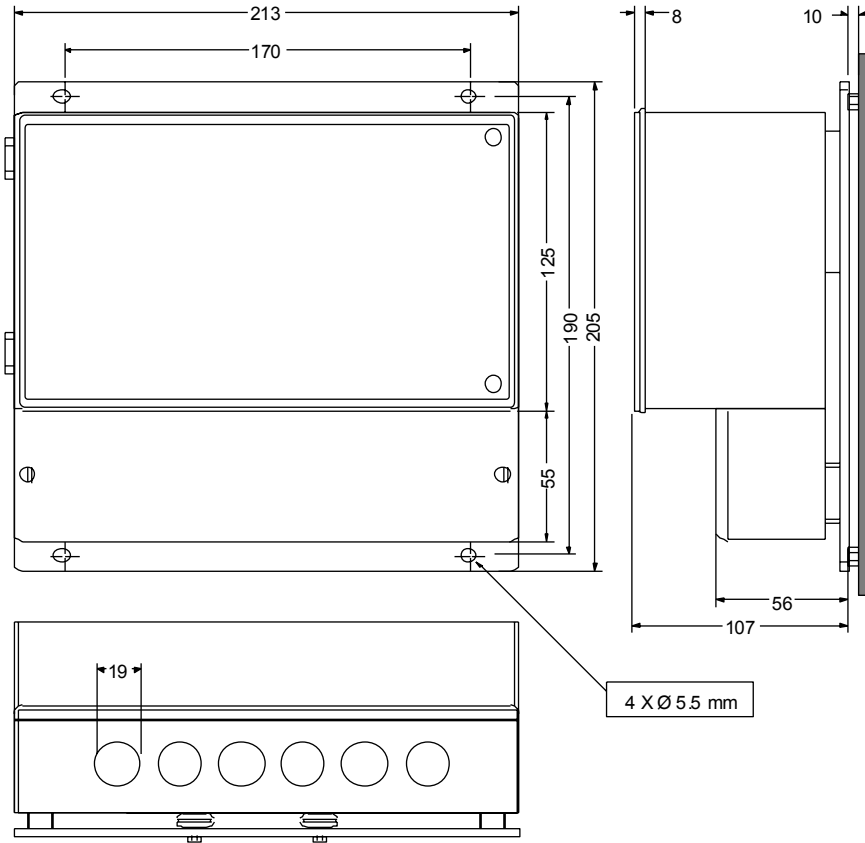

Fig. 12

P35AC

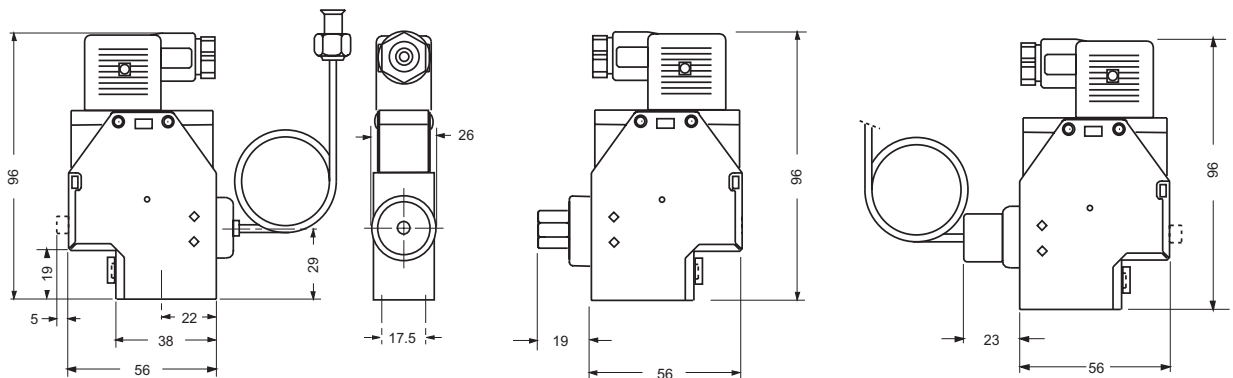

Fig. 13A

Fig. 13B

Fig. 13C

Specifications

Product type	P255MM/ML	
Pressure range	22 to 42 bar 4 to 24 bar 8 to 14 bar	
Maximum overrun pressure	22 to 42 bar = 48 bar 4 to 24 bar = 40 bar 8 to 14 bar = 34 bar	
Pressure connection	style 13, style 45A, style 50 (all with 90 cm of capillary) style 47 (direct mount)	
Control action	direct/reverse	
Maximum output voltage	≥ 96% of supply voltage	
Maximum current	5 A per phase (rms)	
Minimum current	100 mA per phase (rms)	
Power factor (cosφ) motor	≥ 0.6	
Power consumption	nominal 1.5 VA	
Mains supply voltage	P255ML 230 Vac 3 phase +10 % / -15% P255MM400 Vac 3 phase +10 % / -15%	
Mains supply frequency	50/60 Hz	
Operating ambient temp.	-25 to +50 °C	
Operating /storage ambient humidity.	10 to 98 % R.H. (non-condensing)	
Storage ambient Temp.	-40 to 70 °C	
Max. speed adjustment	55 to ≥ 96 % of supply voltage	
Min. speed/ cut-off adjustment	30 to 90 % of supply voltage	
Prop. band range	22 to 42 bar	1 to 8 bar
range	14 to 24 bar	1 to 6 bar
range	8 to 14 bar	0.5 to 4 bar
Hysteresis	5 to 70% of the adjusted prop. band	
Enclosure electronic module	IP54	
pressure transducer	IP20	
Fuses	10 Amp. slow blow glass fuse	
Material: case and cover	Polystyrol	
heatsink	aluminium	
press. connection	90 cm copper capillary with brass flare nut	
Shipping weight	2.3 kg	
Residual current motor	in cut-off mode ≤ 15 mA	
Wiring connections P35AC	screw terminals 1 mm ² up to 1½ mm ²	
P38AD	screw terminals 1 mm ² up to 2½ mm ²	
Dimensions	213 x 205 x 117 (WxHxD)	

The performance specifications are nominal and conform to acceptable industry standards. For applications at conditions beyond these specifications, consult the local Johnson Controls office or representative. Johnson Controls shall not be liable for damages resulting from misapplication or misuse of its products.



Johnson Controls International, Inc.

Headquarters: Milwaukee, WI, USA
 European Headquarters: Westendhof 8, 45143 Essen, Germany
 European Factories: Lomagna (Italy), Leeuwarden (The Netherlands) and Essen (Germany)
 Branch Offices: Principal European Cities.

This document is subject to change

Printed in Europe