

## TS-9100

### Electronic Sensors and Transducers

#### Introduction

The TS-9100 series of electronic temperature sensors and transducers provides a passive or active signal that corresponds with the air or water temperature in heating, ventilating and air conditioning applications.

They provide either a 0...10V signal directly proportional to the sensed temperature, or a passive resistive signal NTC or Pt 100.

They are primarily designed to be used as an input to a digital controller of the system 9100 family (except for Pt 100), but can be used with other electronic devices.



- Rod TS-910x-82xx with and without well (immersion or duct applications)
- Rod fast response TS-910x-83xx



- Immersion well for cable sensor TS-910x-850x
- Ceiling model TS-910x-870x



- Rod fast response model TS-910x-835x with duct flange TS-9100-8950

#### Features and Benefits

<input type="checkbox"/> Wide range of enclosures and signal outputs	Flexible applications
<input type="checkbox"/> PG 13.5 cable inlet for all models with makrolon housing	Protection against humidity and firm fixation of cable
<input type="checkbox"/> For immersion applications, well can be mounted before rod sensor is mounted	Easy installation and servicing Allows more flexibility in sensor selection
<input type="checkbox"/> Rubber gasket and reduced tube diameter for "rod" and "fast rod response" sensors	Tight fixation to duct and easy installation
<input type="checkbox"/> Different length of tubes and wells for duct and immersion applications	Senses the temperature at the desired location

## Application overview

The TS-9100 series of electronic room temperature sensors and transducers provides, depending on the selected models:

- a 0...10 V signal directly proportional to the sensed temperature.
- an NTC „K2“ resistance signal (see table on page 4).
- an NTC „K10“ resistance signal (see table on page 4).
- a Pt 100 resistance signal (IEC751 platinum sensing element).

The different TS-9100 versions with different output signals can be connected to the controllers of the system 9100 series (see Ordering data below), but can also be used with other electronic devices.

The 0...10VDC temperature transducers receive a +15 VDC supply voltage, available from the system 9100 controllers.

For NTC"K10" sensor the temperature range 20...120°C is only used as input to the SC-9100 controller, while the temperature range 0...50°C is used by the TC-8800 controllers.

## Ordering data

Ordering code	Features				Applications			
	Output signal	Mounting	Length in mm.	Temperature range	DX9100, DC9100, TC9100, SC9100. *1)	TC9102 SC9100	TC8800, SC9100	Controllers or electronic devices with Pt100 inputs
TS-9101-8101	0...10V	Remote element	-	-40...50°C	yes	-	-	-
TS-9101-8103	0...10V	Remote element	-	0...40°C	yes	-	-	-
TS-9101-8104	0...10V	Remote element	-	0...100°C	yes	-	-	-
TS-9101-8212	0...10V	Rod *2)	160mm	-20...40°C	yes	-	-	-
TS-9101-8213	0...10V	Rod *2)	160mm	0...40°C	yes	-	-	-
TS-9101-8214	0...10V	Rod *2)	160mm	0...100°C	yes	-	-	-
TS-9101-8222	0...10V	Rod *2)	200 mm	-20...40°C	yes	-	-	-
TS-9101-8223	0...10V	Rod *2)	200 mm	0...40°C	yes	-	-	-
TS-9101-8224	0...10V	Rod *2)	200 mm	0...100°C	yes	-	-	-
TS-9101-8225	0...10V	Rod *2)	200 mm	0...150°C	yes	-	-	-
TS-9101-8226	0...10V	Rod *2)	200 mm	20...120°	yes	-	-	-
TS-9101-8227	0...10V	Rod *2)	200 mm	50...150°	yes	-	-	-
TS-9101-8232	0...10V	Rod *2)	300 mm	-20...40°C	yes	-	-	-
TS-9101-8233	0...10V	Rod *2)	300 mm	0...40°C	yes	-	-	-
TS-9101-8234	0...10V	Rod *2)	300 mm	0...100°C	yes	-	-	-
TS-9101-8235	0...10V	Rod *2)	300 mm	0...150°C	yes	-	-	-
TS-9101-8252	0...10V	Rod *2)	500 mm	-20...40°C	yes	-	-	-
TS-9101-8253	0...10V	Rod *2)	500 mm	0...40°C	yes	-	-	-
TS-9101-8254	0...10V	Rod *2)	500 mm	0...100°C	yes	-	-	-
TS-9101-8322	0...10V	Rod fast resp.	200 mm	-20...40°C	yes	-	-	-
TS-9101-8323	0...10V	Rod fast resp.	200 mm	0...40°C	yes	-	-	-
TS-9101-8324	0...10V	Rod fast resp.	200 mm	0...100°C	yes	-	-	-

\*1) Or other electronic devices with 0...10 V inputs.

\*2) Rod sensors can either be for: - Duct applications (alone)  
- Immersion applications (with well); See dimension drawings on page 7 and 8.

Ordering code	Features				Applications			
	Output signal	Mounting	Length in mm.	Temperature range	DX9100, DC9100, DR9100, TC9100, SC9100. *1)	TC9102 SC9100	TC8800, TC-8900, SC9100	Controllers or electronic devices with Pt100 inputs
TS-9101-8333	0...10V	Rod fast resp.	300 mm	0...40°C	yes	-	-	-
TS-9101-8353	0...10V	Rod fast resp.	500 mm	0...40°C	yes	-	-	-
TS-9101-8401	0...10V	Outdoor	-	-40...50°C	yes	-	-	-
TS-9101-8402	0...10V	Outdoor	-	-20...40°C	yes	-	-	-
TS-9101-8604	0...10V	Strap-on	-	0...100°	yes	-	-	-
TS-9101-8703	0...10V	Ceiling	-	0...40°C	yes	-	-	-
TE-9100-8501	NTC „K2“	Cable sensor	-	-	-	yes	-	-
TE-9100-8502	NTC „K10“	Cable sensor	-	-	-	-	yes	-
TS-9103-8220	NTC „K2“	Rod *2)	200 mm	-	-	yes	-	-
TS-9103-8250	NTC „K2“	Rod *2)	500 mm	-	-	yes	-	-
TS-9103-8320	NTC „K2“	Rod fast response	200 mm	-	-	yes	-	-
TS-9103-8400	NTC „K2“	Outdoor	-	-	-	yes	-	-
TS-9103-8600	NTC „K2“	Strap-on	-	-	-	yes	-	-
TS-9103-8700	NTC „K2“	Ceiling	-	-	-	yes	-	-
TS-9104-8220	NTC „K10“	Rod *2)	200 mm	-	-	-	yes	-
TS-9104-8230	NTC „K10“	Rod *2)	300 mm	-	-	-	yes	-
TS-9104-8600	NTC „K10“	Strap-on	-	-	-	-	yes	-
TS-9105-8220	Pt 100	Rod *2)	200 mm	-	-	-	-	yes
TS-9105-8230	Pt 100	Rod *2)	300 mm	-	-	-	-	yes
TS-9105-8250	Pt 100	Rod *2)	500 mm	-	-	-	-	yes
TS-9105-8400	Pt 100	Outdoor	-	-	-	-	-	yes
TS-9105-8600	Pt 100	Strap-on	-	-	-	-	-	yes
TS-9105-8700	Pt 100	Ceiling	-	-	-	-	-	yes

\*1) Or other electronic devices with 0...10 V inputs.

\*2) Rod sensors can either be for: - Duct applications (alone)  
- Immersion applications (with well); See dimension drawings on page 7 and 8

## Accessories (order separately)

Order code	Description	Material	Length	External Diam.(mm)
TS-9100-8950	Duct flange	Stainless steel + brass	--	--
TS-9100-8903	Imm.well	Copper	260 mm.	12
TS-9100-8902	Imm.well	Copper	200 mm.	12
TS-9100-8907	Imm.well	Copper	150 mm.	12
TS-9100-8901	Imm.well	Copper	120 mm.	12
TS-9100-8905	Imm.well	Copper	50 mm.	9
TS-9100-8913	Imm.well	Stainless steel	260 mm.	12
TS-9100-8912	Imm.well	Stainless steel	200 mm.	12
TS-9100-8917	Imm.well	Stainless steel	150 mm.	12
TS-9100-8911	Imm.well	Stainless steel	120 mm.	12
TS-9100-8915	Imm.well	Stainless steel	50 mm.	9

## Application

	No space for pipe insulation	Space for pipe insulation
<b>Immersion well length</b> Item Code	<b>120 mm</b> TS-9100-89x1	<b>120 mm</b> TS-9100-89x1
<b>Rod Sensor length</b> Item Code	<b>160 mm</b> TS-910x-821x	<b>200 mm</b> TS-910x-822x
<b>Immersion well length</b> Item Code	<b>150 mm</b> TS-9100-89x7	<b>200 mm</b> TS-9100-89x2
<b>Rod Sensor length</b> Item Code	<b>200 mm</b> TS-910x-822x	<b>300 mm</b> TS-910x-823x
<b>Immersion well length</b> Item Code	<b>260 mm</b> TS-9100-89x3	--
<b>Rod Sensor length</b> Item Code	<b>300</b> TS-910x-823x	--

**Rod sensor with immersion wells, with or without pipe insulation.**

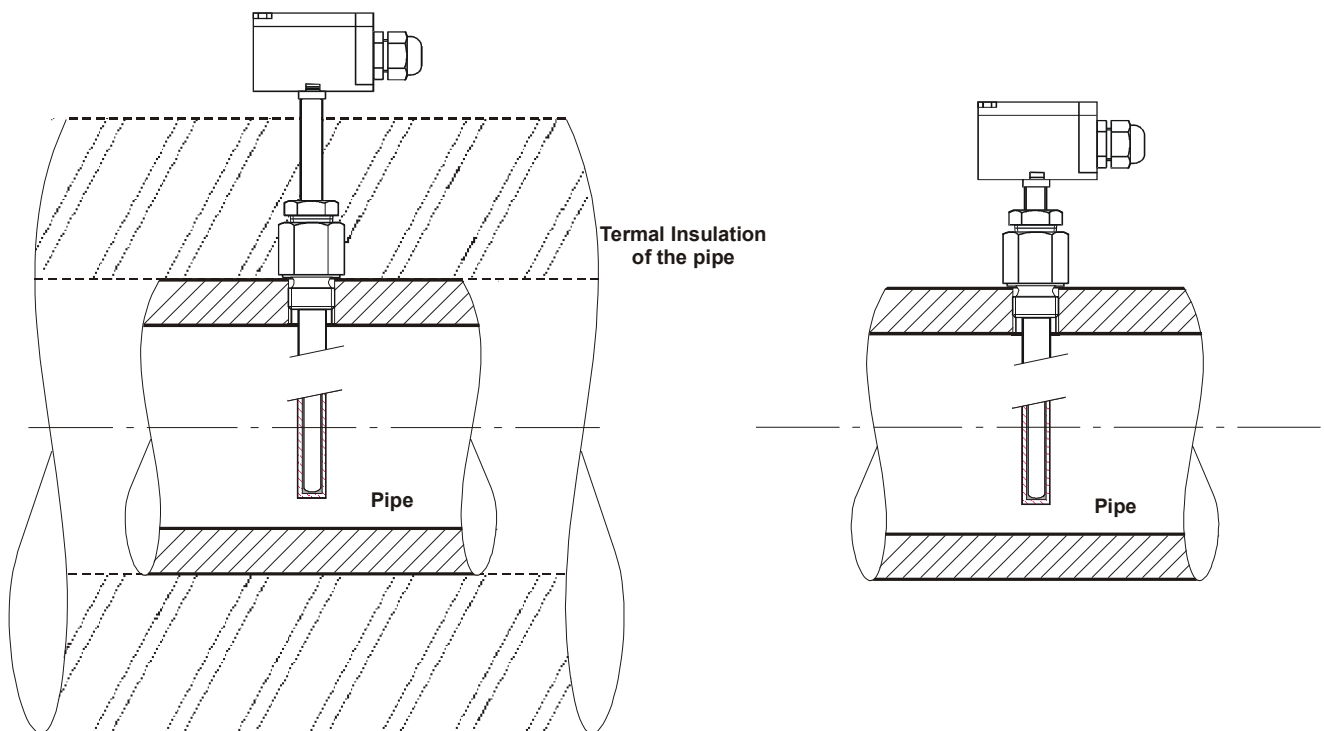

## Mounting and wiring instructions

The TS 9100 can be mounted in virtually any position.

For mounting follow the instructions below:

- Locate the sensors, where they will be exposed to representative conditions.
- Avoid non-representative air draughts, direct sunlight, etc.
- For strap-on models use a thermal conductive paste between well or pipe and sensor to improve reaction times.
- The sensor should not be exposed to direct radiation (lamps, radiators, etc.) or to the sun, since it would lead to incorrect measurement.

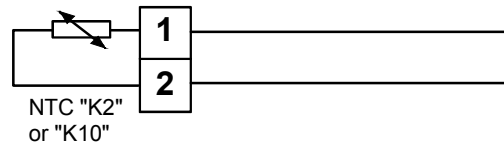

**Wiring diagrams NTC "K2" and "K10" models**

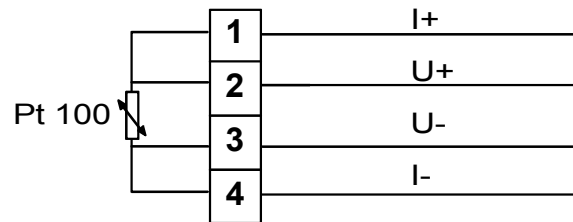

**Wiring diagrams Pt-100 models**

## Wiring instructions

For wiring follow the instructions below:

- All wiring must be in accordance with local regulations and national rules.
- Do not attempt field repairs. If the transmitter is not operating properly, even though it is wired correctly, it should be replaced



### WARNING

When wiring or servicing make sure that:

- the electric voltage to the sensor is switched off to avoid possible damage to the equipment, personal injury or shock.
- you do not touch or attempt to connect or disconnect wires when electric power is on.

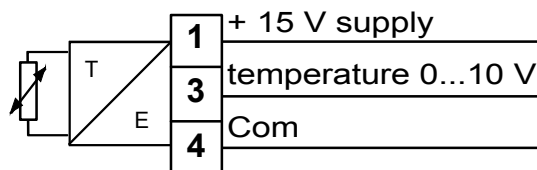

**Wiring diagrams active 0...10 V models**

## Resistance tables

### NTC "K10" models

Temperature in °C	Resistance in $\Omega$
0	32.650
5	25.390
10	19900
15	15710
20	12490
25	10000
30	8057
35	6530
40	5327
45	4370
50	3603
55	2986
60	2488
65	2083
70	1752
75	1479
80	1255
85	1070
90	915.3
95	786.7
100	678.3
105	587.3
110	510.3
115	445.0
120	389.3

### NTC "K2" models

Temperature in °C	Resistance in $\Omega$
0	7352.8
5	5717.8
10	4481.5
15	3537.9
20	2812.8
25	2252.0
30	1814.4
35	1470.6
40	1199.6

### Pt 100 models

The Pt 100 models are equipped with a resistive Pt 100 element according to IEC 751 and DIN 43760. At 0°C the resistance value is 100  $\Omega$ . The accuracy is according to IEC 751 Class A

Temperature in °C	Resistance in $\Omega$
-50	80.31
-45	82.29
-40	84.27
-35	86.25
-30	88.22
-25	90.19
-20	92.16
-15	94.12
-10	96.09
-5	98.04
0	100.00
5	101.95
10	103.90
15	105.85
20	107.79
25	109.73

Temperature in °C	Resistance in $\Omega$
30	111.67
35	113.61
40	115.54
45	117.47
50	119.40
55	121.32
60	123.24
65	125.16
70	127.07
75	128.98
80	130.89
85	132.80
90	134.70
95	136.60
100	138.50

# Dimensions (in mm.)

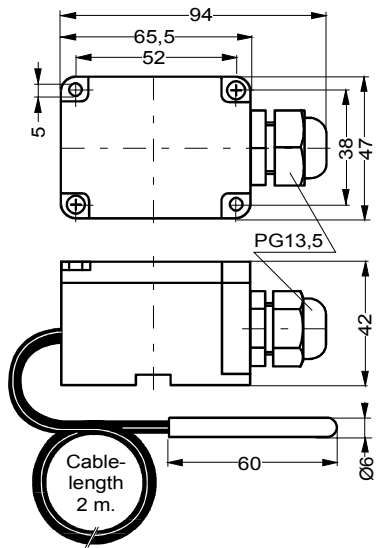

Remote sensor TS-9101-810x

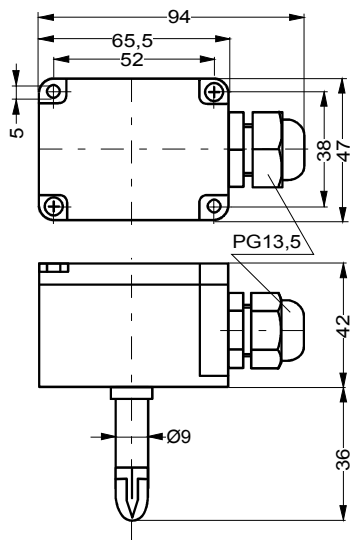

Ceiling sensor TS-910x-870x

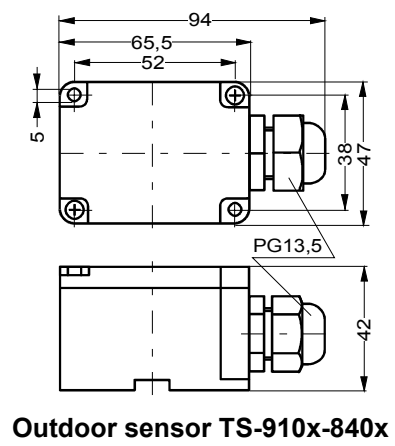

Outdoor sensor TS-910x-840x

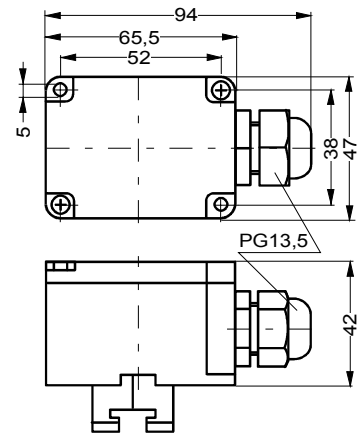

Strap-on sensor TS-910x-860x

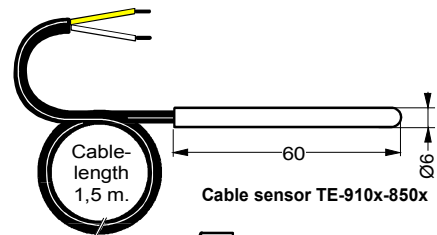

Cable sensor TE-910x-850x

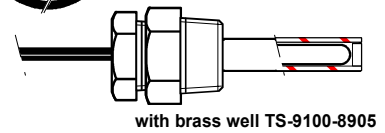

with brass well TS-9100-8905

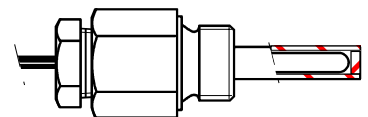

with stainless steel well TS-9100-8915

Cable sensor TE-910x-850

## Dimensions (in mm.) continued

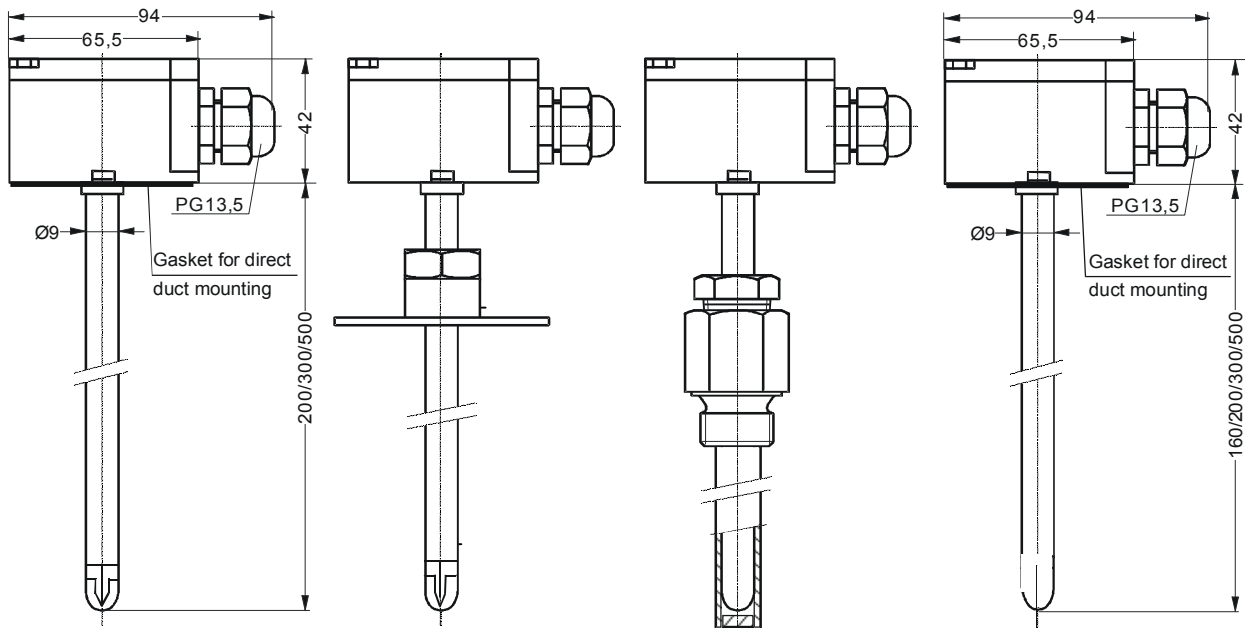

Rod fast response sensor with flange

Rod immersion with or without well

## Accessories

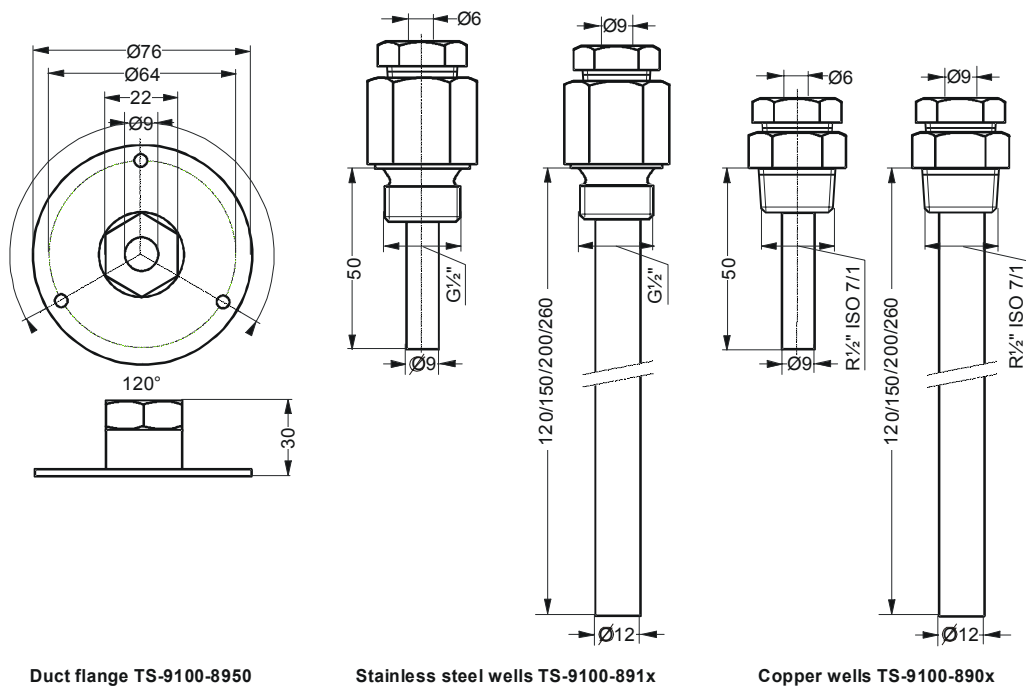

Duct flange TS-9100-8950

Stainless steel wells TS-9100-891x

Copper wells TS-9100-890x

Duct flange and immersion wells

**N**otes:

## Specifications

<b>Sensing Element:</b>	0...10V	NTC „K2“	NTC „K10“	Pt 100
<b>Supply Voltage:</b>	15 VDC $\pm$ 10 %			-
<b>Power Consumption:</b>	0.1 VA (5mA) no load			-
<b>Output signal:</b>	Active 0...10V linear	Resistive NTC „K2“ 2 252 $\Omega$ = 25°C	Resistive NTC „K10“ 10 000 $\Omega$ = 25°C	Resistive Pt 100 100 $\Omega$ = 0°C
<b>Output load:</b>	max. 2mA	-	-	-
<b>Temp. Ranges:</b>	see table on page 2 and 3	0...40 °C	TC-8800: 0...50 °C SC-9100: 20...120 °C	-
<b>Accuracy:</b>	$\pm$ 1 % full scale	$\pm$ 0.2 K range 0...40°C	$\pm$ 0.2 K range 0...120°C	According to IEC 751, class A.
<b>Ambient Operating Conditions:</b>	Maximum for electric connection box: 50°C for transducer (active) 70°C for sensors (resistive)			
<b>Max. medium temperature:</b>	0...10V: max 130°C for range 20...120°C max 110°C for range 0...100°C max 160°C for range 0...150°C max 70°C for all other temperature ranges NTC K2: max 70° C NTC K10: max 120°C Pt100: max 150°C			
<b>Storage Conditions:</b>	-40 to 70°C, 10 to 90 % RH non condensing			
<b>Terminations:</b>	Screw terminals for 1 x 1,5 mm <sup>2</sup> / 14 AWG (maximum) cable			
<b>Housing:</b>	Protection: IP54			
<b>Dimensions:</b>	Depending on model see dimension drawings on page 5 and 6			
<b>Materials:</b>	Rod/outdoor/strap-on/ceiling models: Housing: Polycarbonate Makrolon tube: copper Wells: copper or stainless steel AISI 304			
<b>CE Compliance:</b>	EMC (89/336 EEC) according to the standard EN 50081-1 and EN 50082-1			

The performance specifications are nominal and conform to acceptable industry standards. For application at conditions beyond these specifications, consult the local Johnson Controls office. Johnson Controls, Inc. shall not be liable for damages resulting from misapplication or misuse of its products.

Johnson Controls International, Inc.  
Headquarters: Milwaukee, WI, USA  
European Headquarters: Westendhof 8, 45143 Essen, Germany  
European Factories: Lomagna (Italy), Leeuwarden (The Netherlands), Essen (Germany)  
Branch Offices: principal European Cities  
This document is subject to change without notice

Printed in Europe