

Series P100

Encapsulated Pressure Control.

Auto-reset Standard Duty and Heavy Duty. Manual reset Standard Duty.

Introduction

The P100 Series are encapsulated, non-adjustable, direct mount pressure controls typically used for low and high-pressure cut-outs for OEM applications.

The P100 series are produced according to switchpoint requirements of customers. The small dimensions, weight and protection class makes the P100 series applicable for use without the need of additional mounting brackets.

The P100 Series can be used for all non-corrosive refrigerants like R134a; R22; R404, R410A and others.

Applications include:

- Computer room air conditioning
- Refrigeration/ Air conditioning condensers
- Commercial refrigeration
- Ice machines
- Food service equipment



P100 pressure controls, manual reset (top) automatic reset standard duty with 1/4" male quick-connectors (left) automatic reset heavy-duty (right) and automatic reset standard duty (bottom)

Feature and Benefits

<input type="checkbox"/> Compact size and light weight	Allows direct mounting without the need of mounting brackets
<input type="checkbox"/> Encapsulated, dust tight switch IP67	No pollution by electro-magnetic influences
<input type="checkbox"/> Manual reset models have a trip-free design	Contacts cannot be overridden in the control function
<input type="checkbox"/> Models with gold-plated contacts available.	A minimum current of 5 mA is possible
<input type="checkbox"/> Broad variety of electrical and pressure connections.	Applicable in most applications
<input type="checkbox"/> PED cat IV approved	Applicable as safety device

Description

The pre-set snap-acting disc utilised in the P100 series reverses its shape when pressurised to a selected actuation pressure setting. When the disc snaps, it drives a set of electrical contacts open or close. When the pressure falls to the de-actuation pressure setting, the snap-acting disc and electrical contacts reset to their pre-set position.

Note: For manual reset models the electrical contacts have to be reset manually.

Automatic reset models

Standard automatic reset models are provided with SPST contacts for either "Open High" or "Open Low" function.

Special heavy-duty automatic reset models are available for "Open High" or "Open Low" function and are provided either with heavy-duty SPST contacts or with heavy-duty SPDT contacts.

Manual reset models

These models are available with standard duty "Open High" SPST contacts.

The latching mechanism in the P100 manual reset models provides electrical cut-out even when the reset button is held fully depressed. This trip-free design allows restarting the compressor only when the line pressure has returned to the pre-determined level.

Note

The controls are intended to control equipment under normal operating conditions. Where failure or malfunctioning of the controls could lead to an abnormal operating condition that could cause personal injury or damage to the equipment or other property, other devices (limit or safety controls) or systems (alarm or supervisory systems) intended to warn of or protect against failure or malfunctioning of the controls must be incorporated into and maintained as part of the control system.

Adjustment

These controls are factory set on customers' requirements and are not field adjustable. The trip-points can be selected from here after listed tables.

Note: Manual reset models can only be selected on high trip-point.

Automatic reset models pressure range differentials and tolerances

(A) Actuation pressure range*	(B) Standard tolerance*	(C) Minimum tolerance*	Optimum differential band*	Minimum Release Pressure***	Maximum Release Pressure***
<u>psig</u> bar **	<u>psi</u> bar **	<u>psi</u> bar**	% of Actuation	% of Actuation	% of Actuation
<u>0 to 50</u> 0 to 3,4	<u>± 5</u> ± 0,3	<u>± 4</u> ± 0,3	40-65	30	70
<u>51 to 120</u> 3,5 to 8,3	<u>± 8</u> ± 0,6	<u>± 5</u> ± 0,3	50-75	40	80
<u>121 to 250</u> 8,3 to 17,2	<u>± 10</u> ± 0,7	<u>± 7</u> ± 0,5	60-75	50	80
<u>251 to 350</u> 17,3 to 24,1	<u>± 15</u> ± 1	<u>± 10</u> ± 0,7	60-75	55	80
<u>351 to 500</u> 24,2 to 34,5	<u>± 20</u> ± 1,4	<u>± 10</u> ± 0,7	65-80	60	85
<u>501 to 750</u> 34,6 to 52	<u>± 25</u> ± 1,7	<u>± 15</u> ± 1	70-80	65	85

* At room ambient temperature.

** Values are rounded.

*** Do not use smaller differentials or smaller tolerances as necessary for the application (price consequences)

Manual reset models pressure range and tolerances

Nominal setpoint	Standard tolerance	Minimum tolerance*
$\frac{\text{psig}}{\text{bar}^{**}}$	$\frac{\text{psi}}{\text{bar}^{**}}$	$\frac{\text{psi}}{\text{bar}^{**}}$
200 to 250 14 to 17,2	± 15 ± 1	± 7 ± 0.5
251 to 350 17,3 to 24,1	± 15 ± 1	± 7 ± 0.5
351 to 500 24,2 to 34.5	± 20 $\pm 1,4$	± 7 $\pm 0,5$
501 to 750 34,6 to 52	± 20 $\pm 1,4$	10 0,7

Cut-in pressure is 70% (± 30 PSIG) of the nominal setpoint

Contact functions

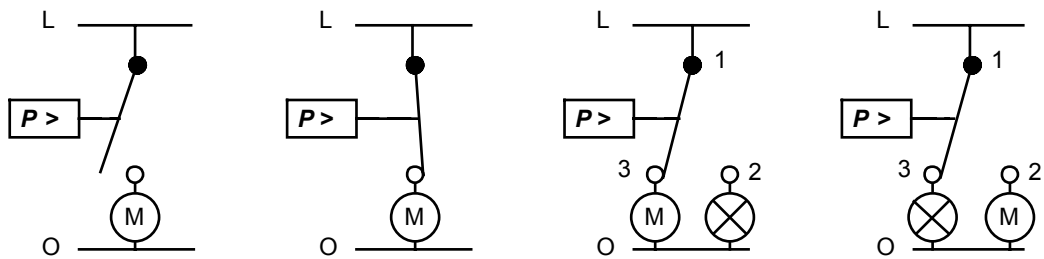

Fig. 1

SPST-NO
LP protection
+ fan-cycling

P100AA,AE

SPST-NC
HP protection

P100CA,DA,CE

SPDT
HP protection

P100EE

SPDT
LP protection

P100EE

Wire leads for SPDT contacts are marked: White = Common (1) Blue = N.O. (2) Black = N.C. (3)

Repair and replacement

Repair is not possible. In case of an improperly functioning control, please check with your nearest supplier.

When contacting the supplier for a replacement you should state the type/model number of the control. This number can be found on the data plate.

Dimensions

Standard duty models
P100AA; CA; DA

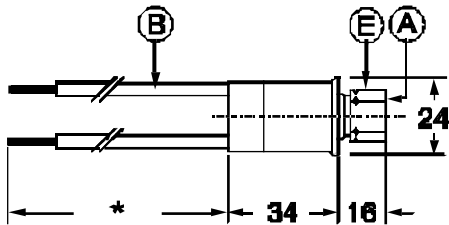

P100AA; CA with leads

Heavy duty models
P100AE; CE; DE

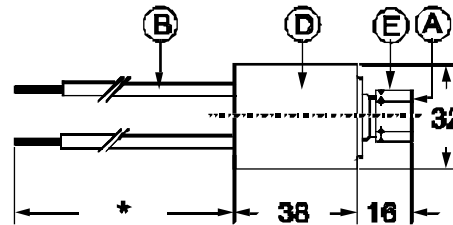

P100AE; CE; EE with leads

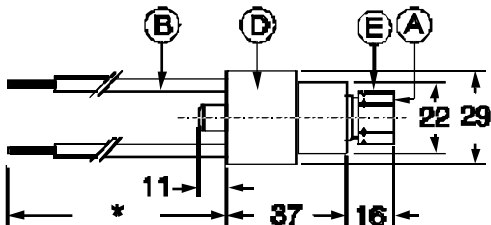

P100DA with leads

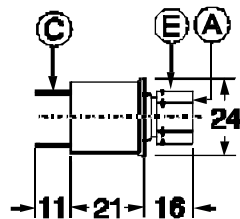

P100AA; CA with quick connect terminals

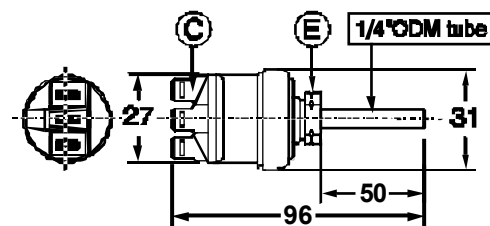

P100EE with quick connect terminals

Fig. 2

- A. 7/16"-20 UNF female flare tube fitting with valve depressor (SAE 1/4").
- B. # 18 AWG (A 0.8 mm²) PVC insulated wire.
- C. 1/4" Quick-connect terminals (6.35 x 0.81 mm).
- D. Nylon sleeve, epoxy filled for environmental seal.
- E. 9/16" HEX.

P100 Specification Worksheet

A: General

- Standard Duty Control (SPST Contacts)
- Heavy Duty Control
 - SPST Contacts
 - SPDT Contacts

B: High Trip Point _____ PSIG
(bar)

C: Auto Reset Models Only

- High trip point tolerance _____ PSI (bar)
- Low trip point _____ PSIG (bar)
- Low trip point tolerance _____ PSI (bar)

Mark one section from each of the category
D through F.

D: Control Construction

- Open high, close low
- Open low, close high
- Open high manual reset (standard duty models only)

E: Electrical Termination

Wire leads with 1/2 " stripped ends.

- 6" 12" 18" 24"
- 30" 36" 42" 48"
- 60" 72"

Without wire leads

- Spade terminals 90" (auto reset models only)
- Screw terminals 90" (heavy duty auto reset models only)
- Spade terminals 45" (heavy-duty SPST models only)
- Screw terminals 45" (heavy-duty SPST models only)
- Other options (please describe)

F: Pressure Connection

Pressure Connection Standard

- 1/4 " Female Flare with Internal Depressor
- Brazed Fittings**
- 2 " Straight 1/4 " Diameter tube
 - 50 mm Straight 6 mm Diameter tube
 - Other options (please describe)

Customer information

Customers Name: _____

Date: _____

Contact Person: _____

Telephone: _____

Brief description of Application: _____

Annual usage (min. order qty 250)

(For P100AP-** and P100CP-** models
min. order qty: 100pcs)

**Mail/Fax complete form to your local
Johnson Controls office**

Specifications

Type number*	P100AA standard duty; P100CA standard duty; P100DA standard duty; P100AE heavy duty; P100CE heavy duty; P100EE heavy duty;	SPST; SPST; SPST; SPST; SPST; SPDT;	open low; open high; open high; open low; open high;	auto. reset. auto. reset. man. reset. auto. reset. auto. reset. auto. reset.
Short term overpressure	Range 20 to 100 PSIG : (1.4 to 6.9 bar) Range 101 to 500 PSIG: (6.9 to 34.5 bar) Range 501 to 750 PSIG: (34.5 to 52 bar)	250 PSIG (17.2 bar) 600 PSIG (41.4 bar) 950 PSIG (65 bar)		
Burst pressure	3500 PSIG (241 bar)			
Life at Rated Current	Auto. reset models : Man. reset models:	100.000 cycles 10.000 cycles		
Temperature	Ambient: Refrigerant:	-30 to + 65 °C (Cable connection) -40 to 135 °C (Quick connect terminals) -55 to +135 °C		
Vibration	15 G max. (between 20 to 2000 Hz)			
Range and differential	See pressure range tables			
Setpoint tolerances	From ± 3 to ± 25 PSIG (± 0.2 to ± 1.7 bar) See pressure range tables.			
Approvals	UL reg. file SA 516 Guide SDFY 2 CSA reg. file LR 63963 Class 1222-01 PED 97/23/EG category IV (TUV) DIN 32733			
Protection Class	IP67 for models provided with wires; IP20 for models provided with QC terminals			
Electrical Ratings	Standard duty : SPST # FLA 2.9 A, LRA 15 A at 240 Vac Pilot duty 375 VA at 120/240 Vac Max. 28 Vdc, 2 A Heavy duty : SPST # FLA 10 A, LRA 45 A at 240 Vac Pilot duty 720 VA at 240 Vac Max. 28 Vdc, 15 A SPDT # NO: FLA 2.9 A, LRA 17.4 A at 240 Vac Pilot duty 728 VA at 240 Vac NC: FLA 10 A, LRA 45 A at 240 Vac Pilot duty 720 VA at 240 Vac Max. 28 Vdc, 15 A			
Electrical connections	1/4" quick connect terminals (6.35 x 0.81 mm) Auto. reset models only. Cable 18 AWG (0.8 mm ²) stranded and tinned copper with 600V 105°C PVC 1/16" insulation. Available for both Auto. Reset models and Man. Reset models in lengths on request in multipliers of 6" (Standard length 48")			
Pressure connections	1/4" Female flare with valve depressor 1/4" ODM solder connection 6 mm ODM solder connection Other connections available on request			

- Quantity orders only
- # FLA = Full Load Amp
RLA = Resistance Load Amp.
LRA = Locked Rotor Amp.

The performance specifications are nominal and conform to acceptable industry standards. For applications at conditions beyond these specifications, consult the local Johnson Controls office or representative. Johnson Controls shall not be liable for damages resulting from misapplication or misuse of its products.

**JOHNSON
CONTROLS**

Johnson Controls International, Inc.

Headquarters: Milwaukee, WI, USA
European Headquarters: Westendhof 8, 45143 Essen, Germany
European Factories: Lomagna (Italy), Leeuwarden (The Netherlands) and Essen (Germany)
Branch Offices: Principal European Cities.

This document is subject to change

Printed in Europe

Notes

Specifications

Type number*	P100AA standard duty; P100CA standard duty; P100DA standard duty; P100AE heavy duty; P100CE heavy duty; P100EE heavy duty;	SPST; SPST; SPST; SPST; SPST; SPDT;	open low; open high; open high; open low; open high;	auto. reset. auto. reset. man. reset. auto. reset. auto. reset. auto. reset.
Short term overpressure	Range 20 to 100 PSIG : (1.4 to 6.9 bar) Range 101 to 500 PSIG: (6.9 to 34.5 bar) Range 501 to 750 PSIG: (34,5 to 52 bar)	250 PSIG (17.2 bar) 600 PSIG (41.4 bar) 950 PSIG (65 bar)		
Burst pressure	3500 PSIG (241 bar)			
Design life	Auto. reset models : Man. reset models:	100000 cycles 6000 cycles		
Temperature	Ambient: Refrigerant:	-30 to + 65 °C -55 to +135 °C		
Vibration	15 G max. (between 20 to 2000 Hz)			
Range and differential	See pressure range tables			
Setpoint tolerances	From ± 3 to ± 25 PSIG (± 0.2 to ± 1.7 bar) See pressure range tables.			
Approvals	UL reg. file SA 516 Guide SDFY 2 CSA reg. file LR 63963 Class 1222-01 DIN 32733			
Protection Class	IP67 for models provided with wires; IP20 for models provided with QC terminals			
Electrical Ratings	Standard duty :	SPST	3(3) A/ 240 Vac Pilot duty 375 VA at 120/240/277 Vac Max. 28 Vdc, 2 A	
	Heavy duty :	SPST SPDT-NC SPDT-NO	10(10) A/240V ac 25(10) A/240V ac 5(3) A/ 240 Vac Pilot duty 480 VA at 120/240/277 Vac Max. 28 Vdc, 15 A	
Electrical connections	1/4" quick connect terminals (6.35 x 0.81 mm) Auto. reset models only. Cable 18 AWG (0.8 mm ²) stranded and tinned copper with 600V 105°C PVC 1/16" insulation. Available for both Auto. Reset models and Man. Reset models in lengths on request in multipliers of 6" (Standard length 48")			
Pressure connections	1/4" Female flare with valve depressor 1/4" ODM solder connection 6 mm ODM solder connection Other connections available on request			

* Quantity orders only

The performance specifications are nominal and conform to acceptable industry standards. For applications at conditions beyond these specifications, consult the local Johnson Controls office or representative. Johnson Controls shall not be liable for damages resulting from misapplication or misuse of its products.

**JOHNSON
CONTROLS**

Johnson Controls International, Inc.

Headquarters: Milwaukee, WI, USA
European Headquarters: Westendhof 8, 45143 Essen, Germany
European Factories: Lomagna (Italy), Leeuwarden (The Netherlands) and Essen (Germany)
Branch Offices: Principal European Cities.

This document is subject to change

Printed in Europe

Instruction sheet

P100

Mounting
Montage
Montagem
Montering
Instalace

Montage
Montaje
Montering
Montering

Montage
Montaggio
Kiinnitys
Μοντρίσιμα

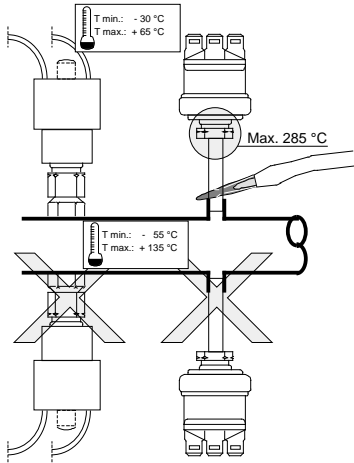

Adjustment
Instelling
Ajuste
Justerung
Seřizenı

Réglage
Ajuste
Justerung
Justerung

Einstellung
Regolazione
Säätö
Püõmıõn

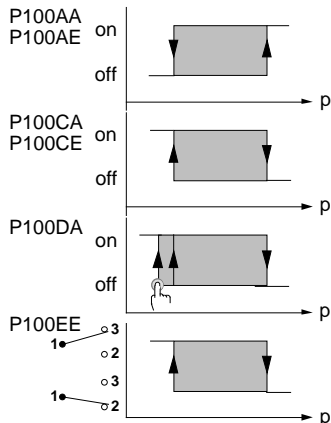

ENGLISH

! READ THIS INSTRUCTION SHEET CAREFULLY BEFORE INSTALLING, RETAIN IT SAFELY FOR FUTURE REFERENCE.

The P100 is a pressure control designed to sense pressure of non-corrosive refrigerants.

According to EN 60730 it is a type 1 action, incorporate control, suitable for direct mount for use in normal pollution situation.

These controls are designed for use only as operating controls. Where an operating control failure would result in personal injury or loss of property it is the responsibility of the installer to add devices or systems that protect against, or warn of, control failure.

Wiring

All wiring should conform to local codes and must be carried out by authorized personnel only. When using multi-stranded wire apply a cable ferrule to the cable end.

! Disconnect from power supply before wiring connections are made to avoid possible electrical shock or damage to equipment.

Adjustment

All controls have fixed setpoints (refer to data label) and cannot be field adjusted.

1. White = Common 2. Blue = N.O. 3. Black = N.C.

Check out procedure

Before leaving the installation observe at least three complete operating cycles to be sure that all components are functioning correctly. If not contact your supplier.

FRANÇAIS

! LISEZ ATTENTIVEMENT CES INSTRUCTIONS AVANT DE COMMENCER L'INSTALLATION ET CONSERVEZ-LES POUR VOUS Y REFERER ULTERIEUREMENT

Le modèle P100 est un régulateur de pression destiné à détecter la pression de réfrigérants non corrosifs.

Selon EN60730, il s'agit d'un contrôle à action de type 1 intégré pour installation directe et pour utilisation dans des conditions de pollution normales.

Cet appareil est destiné à assurer des fonctions de régulation. Lorsque la panne ou le mauvais fonctionnement de ce dernier risque d'entraîner des dommages matériels ou corporels, il est de la responsabilité de l'installateur de prévoir des organes de sécurité indépendants afin de ne pas utiliser le régulateur en équipement de sécurité.

Câblage

Tous les raccordements doivent être conformes aux normes en vigueur et ne peuvent être réalisés que par du personnel autorisé. En cas d'utilisation de câble souple multi-brins, utiliser un embout à sertir.

! Débranchez l'appareil de l'alimentation avant de connecter les câbles pour éviter tout choc électrique ou pour éviter d'endommager l'appareil.

Réglage

Tous les contrôles ont des points de consigne fixes (voir étiquette de données) et ne peuvent pas être réglés sur site.

1. Blanc = Normal
2. Bleu = Ouvert normalement
3. Noir = Fermé normalement

Procédure de contrôle

Après avoir terminé l'installation, observez au moins trois cycles complets de fonctionnement pour s'assurer que tous les composants fonctionnent correctement. Si cela n'est pas le cas, contactez votre fournisseur.

DEUTSCH

! BITTE LESEN SIE DIESE ANWEISUNGEN VOR DER INSTALLATION SORGFÄLTIG DURCH UND BEWAHREN SIE SIE ZUR WEITEREN VERWENDUNG AUF.

Der P100 ist ein Druckregler zum Fühlen des Drucks nichtagressiver Kühlmittel.

Dies ist entsprechend EN 60730 ein integriertes Regel- und Steuergerät, Wirkungsweise Typ 1, geeignet für direkte Montage unter Umgebungsbedingungen mit üblicher Verunreinigung.

Diese Regler sind ausschließlich zur Verwendung als Bedienelemente vorgesehen. In Situationen, in denen das Versagen eines Bedienelementes Personenschäden oder Sachverluste nach sich ziehen kann, ist der Installateur dafür verantwortlich, entsprechende Vorrichtungen oder Systeme einzubauen, die einem Regelversagen entgegenwirken oder die als entsprechende Frühwarnsysteme dienen.

Verdrahtung

Alle Verdrahtungen müssen den am Einsatzort geltenden Vorschriften entsprechen und sind ausschließlich dazu bestimmten Personen vorbehalten. Bei Verwendung feindrähtiger Leitungen sind Adernendhülsen zu verwenden.

! Vor dem Herstellen der Drahtverbindungen von Stromversorgung trennen, um das Risiko eines elektrischen Schocks oder Geräteschadens zu vermeiden.

Einstellung

Alle Regler verfügen über fest eingestellte Sollwerte (siehe Typenschild) und können nicht vor Ort eingestellt werden.

1. Weiß = Gemeinsam 2. Blau = Öffner 3. Schwarz = Schließe

Überprüfung

Vor dem Verlassen der Anlage sollten Sie diese mindestens drei Betriebszyklen beobachten und überprüfen, daß alle Komponenten ordnungsgemäß funktionieren. Sollte dies nicht der Fall, wenden Sie sich bitte an Ihren Händler.

NEDERLANDS

! NEEM DEZE INSTRUCTIES GRENDDIG DOOR ALVORENS U BEGINT MET HET INSTALLEREN EN BEWAAR ZE VOOR TOEKOMSTIG GEBRUIK

De P100 is een pressoostaat ontworpen voor het meten van drukken van niet corrosieve koelmiddelen.

Volgens EN 60730 is het een type 1 actie, in te bouwen apparaat, geschikt voor directe montage in een normaal vervuilde omgeving.

Deze apparaten zijn alleen ontworpen voor gebruik als regelaar. Als een foutieve werking van de regelaar persoonlijk letsel of schade kan veroorzaken, moet de installateur beveiliging of alarm apparatuur aansluiten die aangeeft dat de regelaar niet functioneert.

Bedrading

De installatie, de elektrische aansluiting en de instellingen dienen overeen te stemmen met de plaatselijke voorschriften en mogen enkel worden uitgevoerd door bevoegd personeel. Indien een draad met flexibele kern wordt toegepast dient het uiteinde van de draden te worden voorzien van een ader eindhuls.

! Schakel de voedingspanning af voordat de bedrading wordt aangebracht om elektrische schokken of beschadiging van de apparatuur te voorkomen.

Instelling

Alle apparaten hebben een vaste instelling (zie data label) en kunnen niet worden gewijzigd.

1. Wit = Algemeen contact
2. Blauw = Normaal Open contact
3. Zwart = Normaal Gesloten contact

Controleprocedure

Controleer, voordat u de installatie zelfstandig laat werken, gedurende ten minste drie complete werkcycli of alle onderdelen correct werken. Werkt de installatie niet correct, neem dan contact op met uw leverancier.

ESPAÑOL

! LEA DETENIDAMENTE ESTA HOJA DE INSTRUCCIONES ANTES DE REALIZAR LA INSTALACION Y GUARDELA PARA FUTURAS CONSULTAS

El P100 es un control de presión diseñado para detectar la presión de refrigerantes no corrosivos.

Según la normativa EN 60730, se trata de un control incorporado de mando de tipo 1, adecuado para montaje directo, para su utilización en situaciones normales de contaminación.

Estos controles están diseñados para ser utilizados solamente como controles de funcionamiento. En los casos en que un fallo de control de funcionamiento pudiera producir daños personales o a propiedades, es responsabilidad del instalador añadir los dispositivos o sistemas que protejan o adviertan de los fallos de control.

Cableado

Todo el cableado debe cumplir las normativas locales y debe realizarse solamente por el personal autorizado. Cuando se utiliza cable flexible aplicar terminales en los extremos.

! Desconecte la fuente de alimentación antes de realizar las conexiones del cableado para evitar posibles descargas eléctricas o daños en los equipos.

Ajustes

Todos los controles tienen puntos de ajuste fijos (consulte la etiqueta de especificaciones) y no pueden realizarse ajustes de campo.

1. Blanco = común 2. Azul = Normalmente abierto
3. Negro = Normalmente cerrado

Procedimiento de comprobación

Antes de finalizar la instalación, observe por lo menos tres ciclos de operación completos para asegurarse que todos los componentes estén funcionando correctamente. Si no es así, póngase en contacto con su proveedor.

ITALIANO

! GERE ATTENTAMENTE LE ISTRUZIONI PRIMA DELL'INSTALLAZIONE E ISERVARE PER FUTURE CONSULTAZIONI

Il dispositivo P100 è un regolatore di pressione in grado di rilevare la pressione di refrigeranti non corrosivi.

Si tratta di un comando incorporato con azioni di tipo 1 in conformità con la EN60730, adatto per montaggio diretto e per essere utilizzato in ambiente con grado di inquinamento normale.

Questi dispositivi hanno esclusivamente la funzione di comandi. Se un comando può provocare danni alle persone o alle cose, è responsabilità dell'installatore aggiungere gli opportuni dispositivi o sistemi di protezione o di segnalazione dello stato di guasto del comando stesso.

Cablaggio

Il cablaggio deve essere conforme alle normative locali ed essere eseguito esclusivamente da personale autorizzato. Quando si usa un cavo con filo a trefoli occorre applicare un capocorda alla fine di ogni filo.

! Togliere tensione prima di eseguire gli allacciamenti per evitare scosse elettriche o danni alle apparecchiature.

Regolazione

Tutti i comandi hanno valori impostati fissi (rilevabili dalla targhetta) e non possono essere regolati sul campo.

1. Bianco = Comune 2. Azzurro = N.A. 3. Nero = N.C.

Messa in funzione

Prima di concludere l'installazione, osservare almeno tre cicli operativi completi per accertare il corretto funzionamento di tutti i componenti. In caso di irregolarità, contattare il proprio fornitore.

PORTUGUÊS

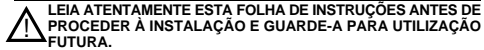

LEIA ATENTAMENTE ESTA FOLHA DE INSTRUÇÕES ANTES DE PROCEDER À INSTALAÇÃO E GUARDE-A PARA UTILIZAÇÃO FUTURA.

O P100 é um controlador de pressão destinado à detecção de pressão de refrigerantes não corrosivos.

De acordo com EN 60730, trata-se de um controlador incorporado de acção de tipo 1, apropriado para montagem directa e utilização em condições normais de poluição.

Estes controladores foram concebidos exclusivamente para a utilização como controladores operacionais. Quando uma falha do controlador operacional possa resultar em ferimentos físicos ou perda de propriedades, recaí sobre o instalador a responsabilidade o acréscimo de dispositivos ou sistemas que protejam ou alertem contra uma falha do controlador.

Conexões

Todas as conexões devem estar conforme os códigos locais e efectuadas somente por pessoal autorizado. Ao ser utilizado cabo multifilar, monte um adaptador de cabo na extremidade do cabo.

⚠ Antes de proceder à conexão de cabos, desligue a alimentação eléctrica para evitar choques eléctricos ou danos ao equipamento.

Ajustes

Todos os controladores têm pontos de referência fixos (consulte a etiqueta de dados) e não podem ser ajustados no local.

1. Branco = contacto comum
2. Azul = normalmente aberto
3. Preto = normalmente fechado

Procedimento de controlo

Antes de abandonar a instalação, observe pelo menos três ciclos de funcionamento completos para assegurar-se de que todos os componentes funcionem correctamente. Do contrário, contacte o seu fornecedor.

SVENSKA



LÄS NOGA DESSA INSTALLATIONSANVISNINGAR INNAN INSTALLATIONEN UTFÖRS OCH BEVARA DEM FÖR FRAMTIDA REFERENS.

P100 är en tryckkontroll som konstruerats för att avkänna trycket av icke-korrosiva kylmedel.

I enlighet med EN 60730 är det en typ 1 funktion, inbyggd styrning, lämplig för direkt montering i en normalt nedsmutsad miljö.

Denna styrenhet är utformad för att användas som opererande styrenhet och skall därför endast användas som sådan. Det är installatörens ansvar att förse installationen med enheter och/eller säkerhetssystem som förebygger att eventuellt skada tillfogas personer eller egendom till följd av driftfel i styrenheten.

Ledningar

All kabeldragning ska utföras enligt gällande bestämmelser och får endast utföras av behörig personal. När det används mångledad kabel, sätt dit i en kabelsko i kabeländarna.

⚠ För att undvika elektrisk stöt eller skada utrustningen ska strömförsörjningen kopplas bort innan anslutningarna utförs.

Justering

Alla styrenheter har fasta inställningspunkter (se datamärkning) och kan inte justeras på fältet.

1. Vit = Gemensam
2. Blå = Normalt öppen
3. Svart = Normalt stängd

Kontrollera proceduren

Efter installationen bör man övervaka minst tre hela operationscyklar fungerar som de ska. Om detta inte är fallet, kontakta leverantören.

SUOMI



LUE TÄMÄ OHJELEHTINEN ENNEN ASENNUSTA HUOLELLISESTI JA SÄILYTÄ SE MYÖHEMMÄN TARPEEN VARALTA

P100 on paineen säädin, joka on tarkoitettu mittaamaan ruostumattomien kylmäaineteiden painetta.

Laitte on EN 60730:n mukaisesti tyyppiä 1 oleva kiinteä toiminnan säädin, joka voidaan asentaa suoraan paikalleen ja jota voidaan käyttää normaalissa saastetilatanteessa.

Nämä ohjausreleet on tarkoitettu vain laitteiston toiminnan ohjaukseen. Jos ohjaushäiriö voi johtaa henkilö- tai aineellisiin vahinkoihin, asentajan velvollisuutena on huolehtia tarvittavista lisälaitteista tai -järjestelmistä, jotka suojaavat ihmisiä ja laitteistoa ohjaushäiriön seurauksilta tai varoittavat häiriöstä.

Kytentä

Johdotus on tehtävä paikallisten määräysten mukaisesti ja sen saa suorittaa vain ammattitaitoinen henkilö. Käytettäessä monisäikeistä johtoa kaapelin holkki tulee kiinnittää kaapelin päähän.

⚠ Katkaise virta ennen johtojen asennusta välttääksesi mahdollisen sähköiskun tai laitteen vahingoittumisen.

Säätö

Kaikkilla säätimillä on kiinteät asetusarvot (katso nimikilpeä) eikä niitä voida säätää paikan päällä.

1. Valkoinen = tavallinen
2. Sininen = normaalisti auki
3. Musta = normaalisti kiinni

Alkutarkastus

Ennen kuin laitteisto jätetään toimimaan ilman valvontaa, sen toimintaa on tarkkailtava ainakin kolme täyden jakson ajan. Täällin on varmistettava, että kaikki komponentit toimivat kunnolla. Jos laitteisto ei toimi asianmukaisesti, ota yhteys sen toimittajaan..

DANSK



LÆS DENNE VEJLEDNING GRUNDIGT FØR INSTALLATION OG GEM DEN TIL SENERE BRUG

P100 er et tryk kontrolapparat designet til føle tryk af rustfrikøleanlæg.

Ifølge EN 60730 er det en type 1 funktion, inkorporeret kontrol, anvendelig til direkte montage, til brug i normalt forurenede omgivelser.

Disse regulatorer er kun beregnet til at blive brugt som driftsregulatorer. Hvis en fejl i en driftregulator kan resultere i fare for personer eller materielle skader, er installatøren ansvarlig for, at der installeres anordninger eller systemer, som beskytter eller advarer mod fejl i regulatoren.

Elektrisk installation

Ledningsføring skal udføres i henhold til lokale forskrifter og må kun udføres af autoriseret personale. Ved anvendelse af flerleder kabel, skal der monteres kabelsko på endene.

⚠ Sluk for strømforsørlsen før den elektriske tilslutning laves, for at undgå elektrisk stød eller beskadigelse af apparaturet.

Justering

Alle kontrol apparater har faste indstillingsværdier (refererer til data mærkaten), og kan ikke indstilles på ny.

1. Hvid = Almindelig
2. Blå = Normal åben
3. Sort = Normal lukket

Test procedure

Før installationen afsluttes. Observer mindst tre komplette betjenings cyklusser, for at være sikker på, at alle komponenter fungerer korrekt. Hvis det ikke er tilfældet, tag kontakt med Deres leverandør.

NORSK



LES DENNE VEILEDNINGEN GRUNDIG FØR INSTALLERING, OG GJEM DEN FOR FREMTIDIG BRUK.

P100 er en trykkregulator som er konstruert for føling av trykk i ikke-korrosive kjølemidler.

I henhold til EN60730 er dette en type 1-funksjons, innebygd regulator, som er egnet til direkte montering for bruk i situasjoner med normal forurensing.

Disse regulatorene er kun konstruert for bruk som driftsregulatorer. Hvis en feil på en driftsregulator kan føre til fare for personer eller materielle skader, er det installatørens ansvar å sørge for installering av anordninger eller systemer som beskytter mot, eller advarer om, feil på regulatoren.

Kabling

Kabling skal utføres i samsvar med lokale forskrifter og må bare utføres av autorisert personell. Ved bruk av fler-trådig kabel, bruk kabelsko på endene.

⚠ For å forebygge eventuelt elektrisk søt eller skade på utstyret, må strømforsyningen frakoples før ledninger tilkoples.

Justering

Alle regulatorer har faste settpunkter (se dataetikett) og kan ikke justeres på bruksstedet.

1. Hvit = Felles
2. Blå = Normalt åpen
3. Svart = Normalt lukket

Kontrollprosedyre

Før installasjonen forlates, må man observere minst tre komplette drifts-sykluser, og være sikker på at alle komponenter fungerer riktig. Hvis ikke må leverandøren kontaktes.

ΕΛΛΗΝΙΚΑ



ΔΙΑΒΑΣΤΕ ΠΡΟΣΕΚΤΙΚΑ ΑΥΤΕΣ ΤΙΣ ΟΔΗΓΙΕΣ ΠΡΙΝ ΑΡΧΙΣΤΕ ΤΗΝ ΕΓΚΑΤΑΣΤΑΣΗ ΚΑΙ ΦΥΛΑΞΤΕ ΤΙΣ ΓΙΑ ΜΕΛΛΟΝΤΙΚΗ ΧΡΗΣΗ

Η συσκευή P100 είναι μονάδα ελέγχου πίεσης, σχεδιασμένη να μετρά την πίεση μη διαβρωτικών ψυκτικών μέσων.

Σύμφωνα με το πρότυπο EN 60730 είναι ενσωματωμένη μονάδα ελέγχου δράσης τύπου 1, κατάλληλη για άμεση τοποθέτηση και για χρήση σε κανονικές συνθήκες ρύπανσης.

Αυτοί οι μηχανισμοί ελέγχου έχουν σχεδιαστεί ώστε να χρησιμοποιηθούν αποκλειστικά ως ελεγκτές λειτουργίας. Αποτελεί ευθύνη του τεχνικού εγκατάστασης να προσθέσει μηχανισμούς ή συστήματα αποτροπής ή προειδοποίησης βλαβών του ελεγκτή, ώστε να αποτραπεί το ενδεχόμενο πρόκλησης οωματικών βλαβών ή υλικών ζημιών στην περίπτωση κάποιας δυσλειτουργίας του ελεγκτή.

Καλωδίωση

Όλες οι καλωδιώσεις θα πρέπει να συμμορφώνονται με τους τοπικούς κανονισμούς και να πραγματοποιούνται μόνο από εξουσιοδοτημένο προσωπικό. Αν χρησιμοποιείτε πολύκλωνο καλώδιο, βάλτε ένα κατάλληλο συνδετήρα στο άκρο του καλωδίου.

⚠ Αποσυνδέστε τη συσκευή από το ρευματολήπτη πριν τη σύνδεση των καλωδίων για να αποφύγετε τον κίνδυνο ηλεκτροπληξίας ή βλάβης της συσκευής.

Ρύθμιση

Όλες οι διατάξεις ελέγχου έχουν σταθερές τιμές αναφοράς (βλ. ετικέτα με τα σχετικά στοιχεία) και δεν είναι δυνατό να ρυθμιστούν επιτόπου.

1. Λευκό = Συνήθης
2. Μπλε = Κανονικά κλειστή
3. Μαύρο = Κανονικά ανοιχτή

Διαδικασία τελικού ελέγχου

Πριν φύγετε από το χώρο της εγκατάστασης, παρατηρήστε τουλάχιστον τρεις κύκλους λειτουργίας για να βεβαιωθείτε ότι όλα τα τμήματα λειτουργούν σωστά. Σε διαφορετική περίπτωση, καλέστε τον προμηθευτή του υλικού. Η καθυστέρηση θα πρέπει να ελέγχεται μετά το τέλος της διαδικασίας εγκατάστασης αλλά και σε τακτά χρονικά διαστήματα.

ČESKY

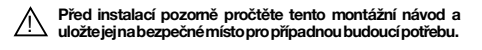

Před instalací pozorně pročtěte tento montážní návod a uložte jej na bezpečné místo pro případnou budoucí potřebu.

P100 je tlakový regulátor určený pro snímání tlaku nekorozivního chladiva.

Podle EN 60730 je jeho provoz typu 1, nezávisle instalovaný regulátor vhodný pro přímou montáž v podmínkách běžného znečištění.

Tyto regulátory jsou určeny pro použití pouze jako provozní. Pokud by jejich selhání způsobilo zranění osob nebo poškození majetku, je povinností osoby provádějící instalaci připojit zařízení nebo systémy, které ochraňují nebo varují před selháním regulátoru.

Zapojení

Veškeré zapojení musí odpovídat příslušným normám a musí být provedeno pouze odpovědnými osobami. Při použití vícepramenného vodiče nalisujte na jeho odizolovaný konec zakončovací dutinku.

⚠ Abyste zamezili možnosti vzniku úrazu elektrickým proudem nebo poškození zařízení, odpojte před elektrickou montáží přívod napájení.

Nastavení

Všechny regulátory mají pevné body nastavení (viz výrobní štítky jednotlivých typů), jejich nastavení nelze v provozu měnit.

1. Bílá = společný
2. Modrá = v základní poloze otevřený
3. Černá = v základní poloze zavřený

Kontrola

Před tím, než opustíte instalované zařízení, zkontrolujte alespoň tři kompletní provozní cykly, abyste se ujistili, že všechny součásti pracují správně. V opačném případě se spojte se svým dodavatelem.